

# Houston's Future as a Global Center for Clean Hydrogen Manufacturing, Recycling, and Electrolysis

Prepared for the Center  
for Houston's Future

13-December-2022

# Contents

Contents .....	ii
Figures .....	iv
Hydrogen basic conversions .....	vi
Terms and acronyms .....	vi
Executive Summary .....	viii
<b>1. Introduction .....</b>	<b>1</b>
1.1. Houston background and current status .....	1
1.2. The role of low carbon hydrogen in energy transition .....	2
1.3. Motivating policy .....	4
1.4. Exclusions and limitations .....	5
<b>2. Stakeholder identification and engagement .....</b>	<b>6</b>
2.1. Stakeholder definitions .....	6
2.2. Main value chain participants .....	7
2.3. Consultation summary .....	8
2.4. Stakeholder highlights .....	9
<b>3. Current strengths .....</b>	<b>12</b>
3.1. Overall competitive position amongst hubs .....	12
3.2. Willingness of companies to relocate .....	15
3.3. Available labour pool .....	17
<b>4. Transitioning manufacturing and services base .....</b>	<b>20</b>
4.1. Establishing hydrogen manufacturing zones .....	20
4.2. Perception challenges and policy needs .....	22
4.3. Component standardization .....	23
4.4. Energy service companies transitioning into hydrogen .....	24
4.5. Modular construction .....	25
<b>5. Expanding electrolyzer market .....</b>	<b>26</b>
5.1. Market history and growth trends .....	26
5.1.1. Growth by global region .....	26
5.1.2. US electrolyzer market .....	27
5.1.3. Growth by electrolyzer technology .....	28
5.2. Capital cost improvement .....	29
5.2.1. Learning rates .....	30
5.2.2. Alkaline .....	31
5.2.3. PEM .....	33
5.2.4. SOEC .....	35
5.2.5. Balance of plant .....	36
5.3. Critical materials supply chains .....	39
5.3.1. General metals demand .....	39
5.3.2. Platinum group metals importance .....	40

5.3.3.	Advanced carbon materials.....	44
5.4.	Emerging policies prioritising green hydrogen.....	45
5.4.1.	Guarantees of origin .....	45
5.4.2.	Direct subsidies for production .....	46
5.4.3.	Subsidies bridging green hydrogen cost .....	47
5.4.4.	Establishment of cost indexes.....	47
5.4.5.	Research and Development (R&D).....	48
5.5.	Rate of capital investment .....	49
5.5.1.	Investment requirements .....	50
5.5.2.	Profitability challenges .....	50
5.5.3.	Estimate of Houston hub development.....	51
6.	Hydrogen system development and deployment.....	52
6.1.	Green versus blue hydrogen .....	53
6.2.	Incentives provided for deployment .....	53
6.3.	Large renewable resources with constrained electrical grid access.....	53
6.3.1.	Onshore renewables (wind and solar).....	54
6.3.2.	Offshore wind .....	55
6.4.	Globally focused design-build firms support industry conversion .....	55
6.4.1.	Integration between EPCs and energy firms.....	56
6.4.2.	Case study – Trinidad and Tobago.....	56
6.5.	Regional participants .....	56
7.	Actions.....	58
7.1.	Secure critical materials.....	58
7.2.	Establish industrial zones.....	59
7.3.	Establish foundational projects to stimulate demand .....	59
7.4.	Stakeholder and investor engagement and communication .....	60
	Appendix A - Green hydrogen technology .....	62
	Appendix B - Multi-Criteria Analysis methodology.....	81
	References.....	84

## Figures

Figure 1: Alternate methods of hydrogen production .....	3
Figure 2: Profile of hydrogen applications.....	3
Figure 3: Selected PEM supply chain participants .....	7
Figure 4: Stakeholders evaluated by role .....	8
Figure 5: Operational profile for included stakeholders.....	8
Figure 6: Examples of US hydrogen hubs .....	12
Figure 7: Aggregate performance of Texas hub compared to other us and international locations.....	13
Figure 8: Aggregate performance comparison between Houston and other major USA hubs .....	13
Figure 9: Differentiating criteria for Houston compared to other us hubs .....	14
Figure 10: Map of selected US manufacturing facilities, component providers and announced expansions .....	15
Figure 11: Stakeholder likelihood to expand Houston based supply chain, by current Houston presence.....	16
Figure 12: Stakeholder likelihood to expand Houston based supply chain, by stakeholder type.....	17
Figure 13: Counties within states with highest relevant workforce.....	17
Figure 14: Available related workforce within proposed hubs .....	18
Figure 15: Related workforce concentration – greater metropolitan areas within hubs.....	19
Figure 16: Potential opportunity zones in Houston .....	21
Figure 17: Opportunities for Greenfield development .....	22
Figure 18: Land and space use compared to ease of doing business for cities in compared hubs, 2021 .....	22
Figure 19: Modular layout for 12 x 40 mw PEM system .....	25
Figure 20: Historical and forecast annual electrolyzer shipments by region .....	27
Figure 21: Hydrogen supply and manufacturing growth projection to 2050.....	28
Figure 22: Measures contributing to hydrogen cost reduction targets .....	29
Figure 23: Alkaline Facility Cost breakdown (1 MW basis in 2030) .....	31
Figure 24: Alkaline electrolyzer facility direct capex (1 GW basis) .....	31
Figure 25: Projected cost reduction for alkaline electrolyzer (1 MW Basis) .....	32
Figure 26 Benchmark system capex based on large-scale alkaline electrolyzers, 2014 and 2019.....	32
Figure 27: PEM Facility Cost breakdown (1 MW basis in 2030).....	33
Figure 28: PEM Electrolyzer Facility Direct CAPEX (1 GW basis).....	34
Figure 29: Projected PEM electrolyzer facility cost reduction through increased scale in 2020 .....	34
Figure 30: SOEC facility cost breakdown (1 MW basis in 2030) .....	35
Figure 31: SOEC stack cost reduction with increasing manufacturing scale .....	36
Figure 32: SOE cost of materials by component with increasing manufacturing scale.....	36
Figure 33: Breakdown of BoP costs for 1 MW plant as a function of the annual production rate.....	37
Figure 34: BoP cost effect of PEM system capacities .....	37
Figure 35: Cost of components compared for different system capacities .....	38
Figure 36: Estimated levelized demand for selected minerals in electrolyzers .....	41
Figure 37: Global iridium and platinum demand projections .....	41
Figure 38: Production of PGM catalyst through current routes .....	41
Figure 39: World mine production of nickel, platinum, iridium in 2020 .....	42
Figure 40: Platinum imports and exports from the US in 2020 .....	43
Figure 41: Platinum and iridium price over the past 30 years .....	43

Figure 42: Carbon based nanostructures.....	44
Figure 43: IRA hydrogen benefits summary .....	46
Figure 44: Houston hub cumulative installed capacity (incl. replacement) and annual manufactured capacity ...	51
Figure 45: Projected capital value of hydrogen market components.....	52
Figure 46: Renewables and transmission development in 2050 under high development scenario .....	54
Figure 47: Diagram of generic water electrolyzer.....	62
Figure 48: Basic diagrams of an alkaline cell and reactions .....	64
Figure 49: Generalized alkaline full balance of plant design.....	65
Figure 50: Basic diagram of a PEM cell and reaction .....	66
Figure 51: Generalized PEM full balance of plant design.....	67
Figure 52: Basic diagram of an SOEC.....	69
Figure 53: Generalized SOEC full balance of plant design.....	70
Figure 54: Basic diagram of an AEM.....	71
Figure 55: Generalized SOEC full balance of plant design.....	72
Figure 56: Electrolyzer cell composition.....	72
Figure 57: Powder metallurgy process for producing titanium based PTL.....	74
Figure 58: BoP components .....	75
Figure 59: Basic elements of electrolyzer power system.....	76
Figure 60: Power supply for a system with several electrolysis stacks .....	76
Figure 61: Energy flows (simulated) within begin of life electrolyzer system .....	77
Figure 62: Process flow and outline of 300 MW/yr. Alkaline electrolyzer manufacturing facility.....	80

## Tables

Table 1: Roles in the electrolyzer production chain.....	6
Table 2: Key stakeholder messages.....	9
Table 3: Stakeholder likelihood to expand Houston based supply chain .....	15
Table 4: Top global O&G service companies in Houston .....	24
Table 5: Learning rates for different technologies and components .....	30
Table 6: Actions to Secure Critical Materials.....	58
Table 7: Actions to Establish Industrial Zones.....	59
Table 8: Actions to establish foundational projects to stimulate demand.....	59
Table 9: Actions to enhance stakeholder and investor engagement and communication .....	60
Table 10: Bipolar plate materials in different electrolyzer technologies .....	73
Table 11: PTL materials in different electrolyzer technologies .....	73
Table 12: Electrode assembly materials in different electrolyzer technologies .....	74
Table 13: High pressure gaseous hydrogen storage vessel types.....	79
Table 14: Evaluation categories and criteria .....	81
Table 15: MCA performance criteria .....	83
Table 16: Criteria importance .....	83

## Hydrogen basic conversions

Aspect	Conversion
Renewable electricity required for production	<p>≈55 kWh electricity → 1 kg H<sub>2</sub></p> <p>≈185 MJ electricity → 1 kg H<sub>2</sub></p>
Hydrogen production from water electrolysis	<p>≈10 liters demineralized water → 1 kg H<sub>2</sub></p> <p>1 MW Electrolyser → ≈ 18 kg/h</p>
Heat from combustion	<p>1 kg H<sub>2</sub> → 33.3 kWh heat → 120 MJ heat (LHV)</p> <p>1 kg H<sub>2</sub> → 39.4 kWh heat → 142 MJ heat (HHV)</p> <p>1 kg H<sub>2</sub> ≈ 3.8 l gasoline</p>
Power from PEM fuel cell	1 kg H <sub>2</sub> → ≈ 16 kWh electricity (±50% efficiency)
Density	<p>11 Nm<sup>3</sup> ↔ 1 kg H<sub>2</sub></p> <p>48 l @ 350 bar ↔ 1 kg H<sub>2</sub></p> <p>24 l @ 700 bar ↔ 1 kg H<sub>2</sub></p> <p>14 l @ -253°C (liquid) ↔ 1 kg H<sub>2</sub></p>
Production efficiency	65% ( $E_{out}/E_{in}$ , LHV)

Source: (Hydrogenics, 2019)

## Terms and acronyms

Term	Acronym or Abbreviation	Definition
Alkaline Electrolyzer	Alkaline	Refer to Appendix A for detailed description
Anion Exchange Membrane Electrolyzer	AEM	Refer to Appendix A for detailed description
Anode		Positive charge element in electrolyzer stack
Asia Pacific	APAC	Conventional region definition
Balance of Plant	BoP	Additional units necessary around an electrolyzer stack to function and transmit the hydrogen produced into storage or utilization
Cathode		Negative charge element in electrolyzer stack
Electrolyzer Cell	Cell	Hydrogen electrolysis cell containing an anode, cathode and membrane.
Electrolyzer Cell Stack	Stack	Arrangement of electrolyzer cells, typically assembled in series
Engineering, Procure, Construction	EPC	Form of contract used to undertake construction works by private sector on large-scale and complex projects

Term	Acronym or Abbreviation	Definition
Europe, Middle East, and Africa	EMEA	Conventional region definition
Hydrogen Fuel Cell	HFC	Fuel cells consume hydrogen to produce electricity and water
Inflation Reduction Act	IRA	Act approved in 2022 which makes substantial investments in US domestic clean energy and GHG reduction
Load Factor	LF	Percent of an electrolyzer's rated capacity it is performing at
Lower Heating Value	LHV	Measure of available thermal energy produced by a combustion of fuel, excluding the heat of vaporization of condensable products (ex. water)
Membrane		Permeable layer in an electrolyzer cell that hydrogen gas can flow through as it moves from cathode to anode
Millimetre	mm	
Million tonnes	Mt	Typical unit used for national and global hydrogen mass
Oil & Gas	O&G	
Perfluorosulfonic Acid	PFSA	Membrane chemistry
Platinum Group Metal	PGM	
Polyphenylene Sulphide	PPS	Electrolyser cell material
Porous Transport Layer	PTL	
Production Tax Credit	PTC	Per-kWh tax credit based on amount of commodity generated and sold
Proton Exchange Membrane Electrolyzer	PEM	Refer to Appendix A for detailed description
Solid Oxide Electrolyzer Cells	SOEC	Refer to Appendix A for detailed description
United States	US	
United States Dollar	\$US	
Water Electrolysis	Electrolysis	Separation of water into hydrogen and oxygen through an electrical reaction across a membrane

# Executive summary

## Context

Houston holds strategic advantages for becoming a global hydrogen energy hub – specifically for manufacturing equipment key to future hydrogen production and distribution infrastructure in the United States and worldwide. The Center for Houston's Future (CHF) understands these advantages and additional opportunities, as expressed in this report. This new economy will provide significant economic and social benefits as Houston becomes a preeminent global hub for the manufacture and deployment of hydrogen large scale electrolyser facilities. Houston's existing status as a global hub for planning and manufacturing energy systems make it an essential element in any larger scale national plan for transitioning to a hydrogen economy.

To assess the City's potential as a hub for hydrogen and hydrogen equipment manufacturing, analysis was conducted through interviews and consultation with 100+ market players as well as study of global, national, and local conditions – including technological and economic factors. Market players surveyed included:

- Existing businesses with relevance to the supply chain ('suppliers').
- Companies that integrate the components for large-scale electrolyser systems ('integrators').
- Public authorities, institutions and other groups who will create supportive conditions ('enablers').

This engagement confirms Houston's intrinsic strengths and growing opportunities for providing the "picks and shovels" of the green hydrogen gold rush. A deeper understanding of Houston's strengths and opportunities reveals actions the city and CHF can take in establishing and accelerating a hydrogen manufacturing value chain.

## Key findings

Beginning with the oil rush of the early 20<sup>th</sup> century, Houston has risen to become a preeminent global center for the energy industry, encompassing the entire ecosystem from finance, production, and export to equipment production and facility design. Like other world energy market centers, Houston is considering options to maintain a leadership role throughout the great energy transition underway. Establishing a global hydrogen energy hub in Houston is a golden opportunity. Transitioning and growing Houston's industrial manufacturing base to create hydrogen electrolysers, storage, and delivery infrastructure is essential to achieving this aim, and offers a massive economic opportunity.

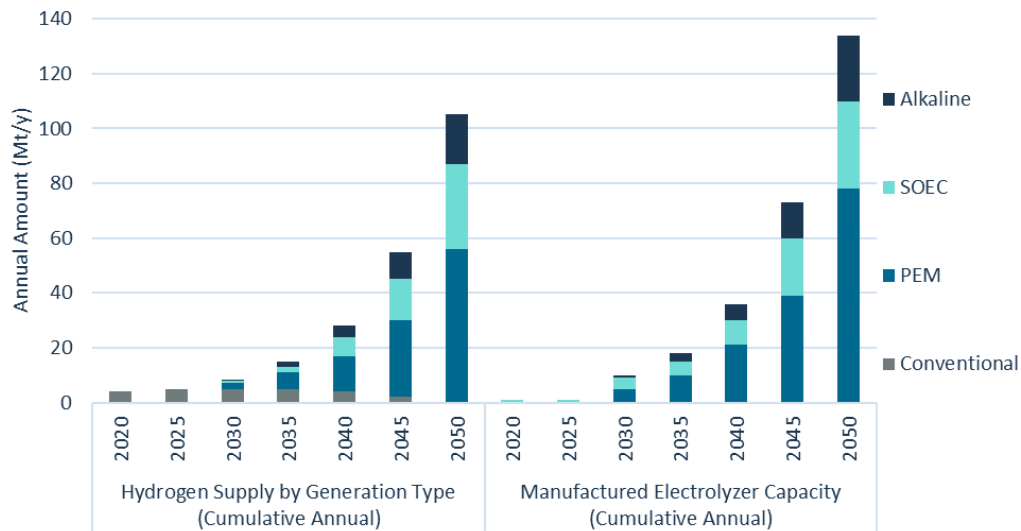
## Manufacturing growth validation

US generation of green hydrogen is predicted to exceed 100 Mt/y by 2050, approximately 20% of the global market. The growth of electrolyzer technologies will vary based on advances and demand for future technologies, but the overall market potential for all technologies is massive and manufacturing capacity for both electrolysers, Balance of Plant (BoP) equipment, and electrolyzer components is currently quite limited. A limited-time, first-mover opportunity is emerging for key manufacturing centers to rise to market pre-eminence by developing quickly.

Houston is well suited to step into this role because its existing manufacturing base is large, sophisticated and is already transitioning to electrolyzer and Balance of Plant (BoP) equipment production. Houston's status in the world energy community has never been based on its access to resources, but rather its ability to supply equipment and planning to best utilize resources regionally, nationally, and globally. Playing to those strengths will be essential as Houston distinguishes its role in a future hydrogen economy, and manufacturing presents significant cost savings through the rapid improvement cycles that agglomeration provides.



Figure 1: Manufacturing capacity expected to increase 20x by 2030, and almost 200x by 2050

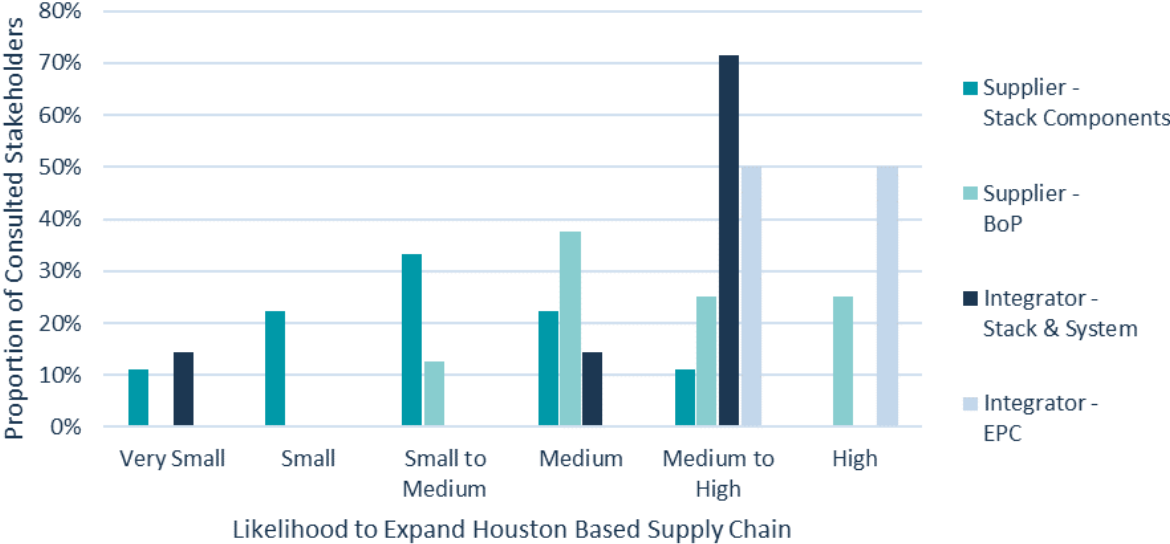


### Corporate location

One of Houston’s greatest strengths is its recognition as a center for energy industrial manufacturing, and a likely continued hub for development. Market players have expressed a strong willingness to move to Houston or to expand their existing footprints. The threshold for this demand varies between individual companies, but all perceive Houston as becoming a global market and a natural opportunity. New players view Houston as a natural place to gain access to finance, market connections, and EPC support, while existing players in the O&G value chain understand they will need to get ahead of the transition already overtaking them.

- Hydrogen electrolyzer stack and system integrators are the primary market players viewing Houston as a major opportunity; they viewed Texas and the Gulf Coast region as likely hubs for hydrogen production and demand, and Houston as a natural center for manufacturing in order to better reach likely customers.
- Engineering, procurement, and construction (EPC) contractors, with global leading energy focused firms already based within Houston, view hydrogen mega-projects as a natural evolution of their services with potentially less business volatility compared to O&G. These groups also viewed many mothballed or abandoned facilities in the Houston area as opportunities for development.
- Balance of Plant (BoP) hydrogen equipment manufacturers are much more varied in location, but many have existing presence. Almost all viewed Houston as a likely center for manufacturing and demand and a key site for long-term expansion but may wait to see who emerged as having the most supportive policies as hub centers – many are smaller companies and cannot afford to incorrectly plan growth.
- Stack component manufacturers emerged as the group least likely to relocate. Manufacturing essential parts such as bipolar plates or electrolyzer membranes, many of these groups are Europe-based and have limited capital for expansion – they are waiting on new location expansion plans out until they see where market surge is occurring. That said, gaining access to these critical supply chain elements will be a central goal for Houston’s hydrogen manufacturing industry to ensure growth and market pre-eminence

**Figure 2: Expectations of many companies were high to move to Houston area, particularly stack and system integrators**

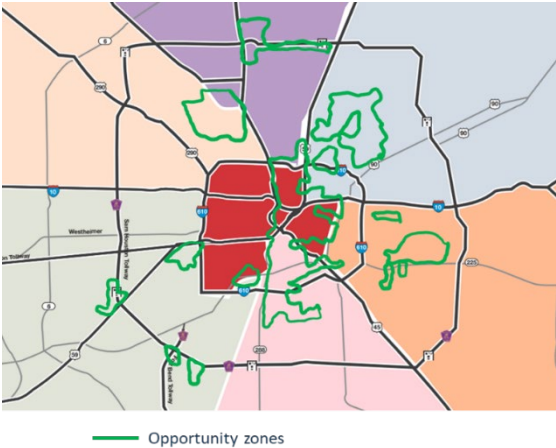


**Hydrogen opportunity zones and policy advantages**

In supporting corporate relocation, Houston was identified as an easy city for companies to move to due to abundant warehouse, land, and logistics support. Houston’s business friendly environment with permitting ease and incentives is widely appreciated. The most recognized advantage is Houston status as its integrated energy economy. Economies of agglomeration occur when companies in related industries are located close enough that the costs of doing business are reduced for all through proximity to sources of supply, demand, R&D, skills, labour, and even motivating competition. For Houston to maintain the same clout in the hydrogen space it enjoys with O&G, zones must be developed to agglomerate these hydrogen companies.

During interviews with manufacturers, SMEs reported a preference for converting existing manufacturing facilities rather than performing greenfield builds (large corporations often planned to enter the area through an acquisition, though they had resources for greenfield builds). Houston’s existing innovation and manufacturing centers will form initial points for concentrated hydrogen development and manufacturing in Houston. Zones with existing manufacturing resources ready for conversion, tax benefits for development, and space for growth were identified.

Figure 3: Potential hydrogen equipment manufacturing zones identified in Houston region



Houston enjoys a reputation as an easy place to do business, and this was called out by many companies in their willingness to establish significant manufacturing presence. Concerns that industries may have had with taking a back seat to O&G have been allayed by the supportive environment that has led to success for start-ups in other sectors such as health and IT.

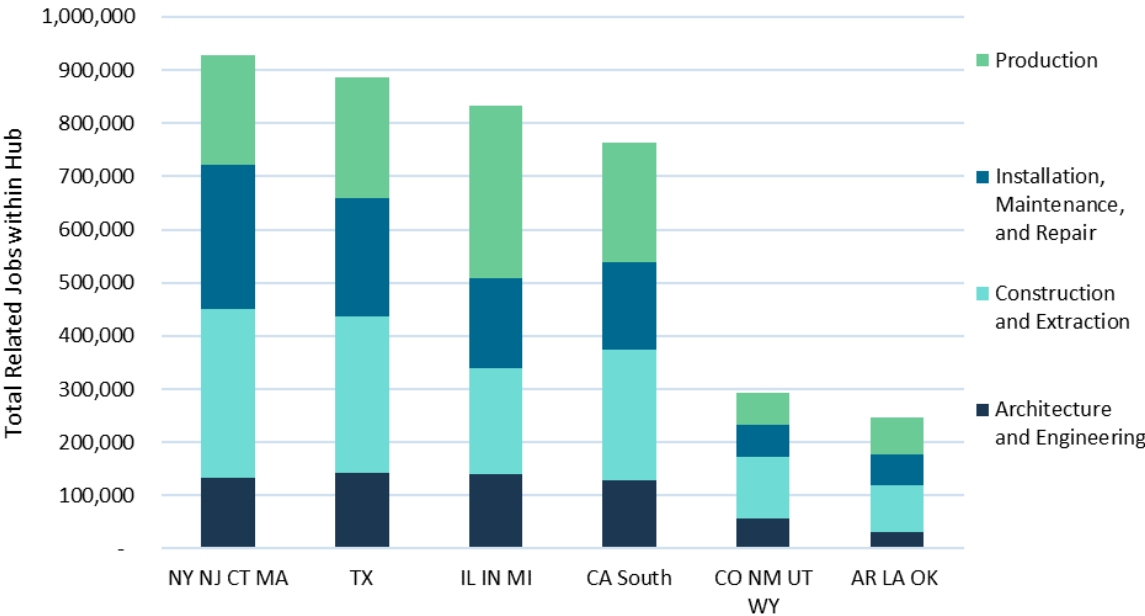
Figure 4: Score for ease of doing business and relative tax rates for major US cities



(Source: Arizona State University)

**Job opportunities**

Identified by many firms as an essential element of their growth plans favoring Houston was its access to a highly skilled labor pool. Though the Houston region did not have the highest concentration of jobs within hydrogen-related fields, the highest concentration (North-eastern US) had to combine several states to reach similar numbers.



Hydrogen was identified by McKinsey and Co’s CHF report as a potential employer of 180,000 within the Houston regional area. The existing O&G work force brings skills in engineering, manufacturing, maintenance, and more that can be almost directly transitioned to hydrogen. Leading employers such as EPC firms stated that their employees are eager to transition. Programs to prime and connect this work force to the hydrogen industry is a primary opportunity area for Houston to distinguish itself as a location where companies can grow with a ready capacity advantage. Leveraging Houston’s existing world-class energy industry ecosystem including finance, services, engineering, manufacturing, and construction provides the means to accelerate hydrogen equipment development and production. This ‘pole position’ will be a source of multi-generational growth.

## Research and development

Houston and the surrounding areas in Texas have an extremely strong background in energy research programs, with university research programs focused on energy and some already substantially focused on hydrogen. Access to these research hubs is appealing to both market entrants and incumbents. They view collaborative research programs as a major advantage and the State of Texas as an excellent corporate research partner. Firms with significant proprietary intellectual property may seek limited protected relationships, but the O&G experience also shows that benefits can still be gained in these situations.

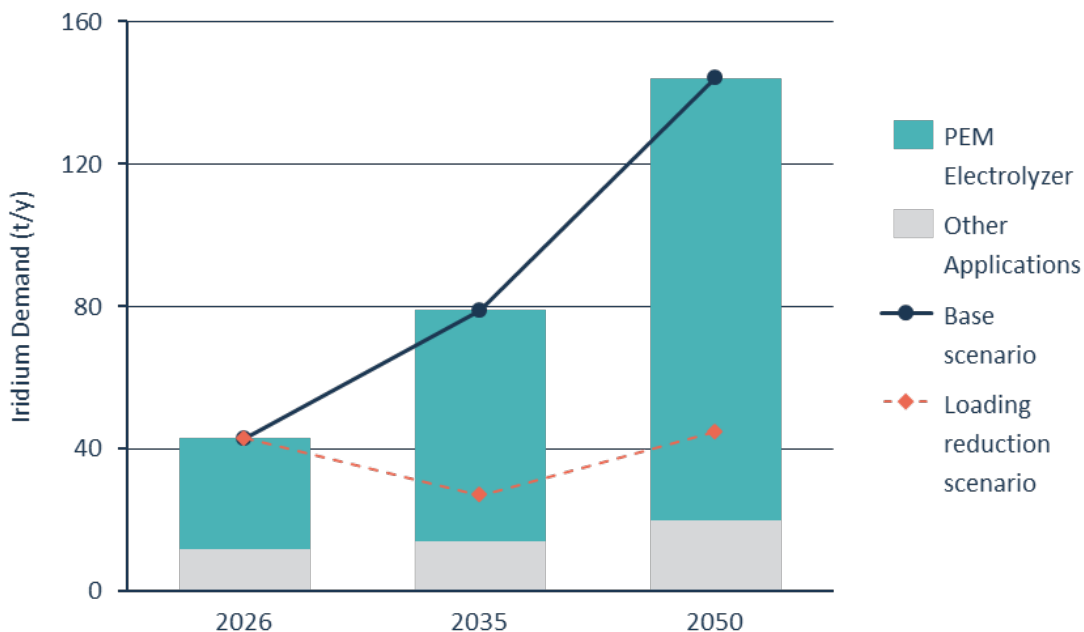
Hydrogen has been subject to extensive R&D support through USDOE, national laboratories (e.g., NREL), university programs, tech incubators, and the private sector – either individually or in consortiums. Frequently national laboratories and universities have been focal points of hydrogen research through their willingness to engage in long-term research profitable to many parties and their willingness to develop partnerships with many players. Texas arguably already has some of the best university hydrogen research programs (such as the University of Texas at Austin's Energy Institute) and tapping into these existing regional resources will be essential for success rather than attempting to recreate them. However, a key finding was that the location of a national lab in Houston focused on hydrogen and advanced energy in Houston would not only bring more R&D into the regional area but would be viewed as a major draw for both large and small players in the hydrogen industry.

## Pain points

Though the development of the hydrogen industry has made national headlines through its double-digit growth, its expansion is only set to grow in the coming years. Some figures put its growth rate through 2040 as high as 35% to hit government and corporate targets – this is likely to create issues in supply chains for manufacturing as they grow at an abnormally fast pace and are forced to confront issues in the market. The report goes into these issues in greater detail, but primary ones identified were:

- **Investment Challenges:** To hit US growth targets for the electrolyzer industry by 2030, \$600B will be required, and \$100B is currently planned. Currently this investment is predominantly moving to hydrogen production projects or electrolyzer stack manufacturers/system integrators, but growth at all points of the supply chain and the distribution/demand networks will be necessary – otherwise key components (such as bipolar plates, which has seen limited investment and is dependent on a few small firms) could become major problems. Houston's status as a center of energy financing could be critical and is a primary argument for its hub status and the ability to draw manufacturing.
- **Critical Material Shortages:** Certain materials such as iridium, carbon fiber (essential for many hydrogen storage technologies), nickel, and platinum are expected to face price hikes and demand shortages as electrolyzer system manufacturing increases. Gaining access to these resources will be critical to continued growth, but some may see demand for electrolyzers alone outstrip current world supply in short order. This requires increased ability to recycled, integration with larger mining plans, and research into reduced material use – Houston could emerge as a major market force through access to critical materials or lose position via lack of access

Figure 5: Electrolyzers could consume 4x world iridium capacity without proper planning



- Balance of Plant (BoP) scale growth: BoP elements in electrolyzer systems represent 60% of value, and many are established technologies. To see declines in cost and increased access to parts (for example, power supply units were called out by several manufacturers as difficult/expensive to acquire), significant scaling will be necessary through standardization and modularization to improve manufacturing capacity.

## Recommendations

As was stated in a number of interviews with major corporate and government stakeholders, “if a hydrogen hub cannot emerge in Houston, it cannot emerge anywhere.” That said, the city should not view the establishment of a hub as a foregone conclusion. Cities and states in other potential hub locations are pursuing aggressive measures to rapidly expand their capabilities in research and manufacturing. The theory of economies of agglomeration holds that once a certain level of development is reached for an energy hub, its natural gravity tends to make it impossible to overcome as a natural headquarters. Though Houston brings many advantages to the table, if these are not utilized to develop manufacturing capacity quickly enough, another center may emerge and be difficult to dislodge. Centralization of manufacturing provides not only a massive economic and employment opportunity, but it is likely to encourage further development of research, production, and demand opportunities in a region. How can Houston encourage this manufacturing opportunity? Over the course of interviews and discussions with stakeholders and market players, a number of recommendations emerged for Houston to rapidly pursue in order to capture the opportunity to emerge as a manufacturing hub – and that emergence as a manufacturing hub would likely cement Houston’s position as a natural leader for hydrogen production planning and development across the US and potentially globally. CHF is advised to take deliberate actions across several areas:

- **Coordinate to ensure future supply of critical materials and components is available for unconstrained growth for market participants**
  - Existing and new supply chains will require adjustment to meet the accelerated production of electrolyzers, and the key pain points identified in the report will need to be addressed to avoid significant blockages in manufacturing capacity
- **Establish zones for electrolyzer manufacturing with a strong competitive value proposition, R&D critical mass and clear incentives**
  - A strong competitive value proposition, and a critical one in Houston’s development as an O&G hub. This builds upon Houston’s strengths in agglomerating related companies in the energy sector.
- **Focus on local development of the high impact, high value portions of the hydrogen equipment supply chain through stimulating demand**
  - Expansion of R&D through key partnerships – including a potential national energy laboratory in the Houston area – and the growth of foundational infrastructure in BoP, components, and essential supply chain elements will ensure a competitive advantage for Houston and support an economy of agglomeration
- **Build acceptance and momentum with local stakeholders and the investment community**
  - Development of regional connections, promotion of existing local/regional suppliers as cornerstones of capacity, deployment/production tracking, hydrogen pricing indexes, and more were identified as showcasing the commitment of Houston and building momentum

# 1. Introduction

Houston, along with the industries and companies residing there, are increasingly asked to redevelop their assets for products incorporating lower carbon feedstocks and energy inputs. Like other energy hubs and producers, Houston is considering options to maintain and promote the competitiveness and market share of its energy and chemicals focused economy. One such opportunity is Houston's evolution into a global hydrogen energy hub. The broad changes associated with the energy transition give rise to new industries and technologies leveraging the infrastructure and human resource base of the Houston area. In particular, the development of an industrial hub to create hydrogen electrolyser plants is a critical opportunity for Houston. The Center for Houston's Future (CHF) has retained Partners in Performance to evaluate Houston's positioning for becoming a global hydrogen electrolyser hub and how this can be achieved.

This report determines Houston is well positioned to become a preeminent global electrolyser manufacturing hub, resulting in significant economic and social benefits. This can happen because:

- The market for hydrogen electrolyzer facilities is rapidly expanding, creating a wealth of opportunities.
- Houston's large industry focused manufacturing base is transitioning to electrolyzer and BoP equipment production.
- Houston's global capability for developing energy and resource projects will increasingly integrate electrolyser technology.

The supporting evidence, actions to be taken to secure this future, and potential outcomes of this hub development are presented within the remainder of this report.

## 1.1. Houston background and current status

Following a series of oil discoveries in the 1900, Houston has grown into a global energy hub. Reduced conventional production was compensated with offshore discoveries and the advent of unconventional onshore production methods. This allowed for the consolidation of an integrated industry with various global energy companies headquartered in the city; leading to its position as a center for finance, planning and more. As a center, it brings together:

- **Energy-related firms** (Lomax, 2017)
  - Home to over 4600 related firms and 1/3 of the US's O&G jobs (237,000).
  - Upstream activities including O&G extraction, oil services, machinery, and fabricated metals.
  - Midstream pipeline construction and management.
  - Downstream including major refining and petrochemical producing.
  - Ancillary industries and utilities.
- **Port of Houston** (Port of Houston, 2022)
  - Largest exporting port in the country also associated with oil and chemicals.
  - Largest container port on the US gulf coast, and the 7<sup>th</sup> largest within the United States.
- **Renewable energy industry**
  - 21 advanced energy R&D centers.
  - 100 solar-related companies and 30 wind-related companies.
- **Wide variety of technical, engineering, legal, consulting and other industry-specific services.**



The proximity of hundreds of industry-specific companies has generated efficiencies and innovation resulting in cost savings for every company within the cluster. The closeness has also acted as a glue binding these industries together as they operate and compete globally.

Texas is the second largest economy in the United States, representing 10% of GDP with annual exports of over \$US 300 billion (Office of the United States Trade Representative, 2019). The economic base, accessible job market and low taxes have led to rapid economic and population growth; Houston has the third highest growth rate in the country, having grown by 200,000 residents since 2010 (Greater Houston Partnership, 2022).

The O&G sector is a major but fickle employer in Houston. As oil prices rise and fall, so do wages and employment in the industry. The recent 2020 decline in oil prices led to major layoffs across Houston (primary and secondary impacts as high as 30,000) as exploration and drilling interest dried up and firms reduced production (Buckley, 2020).

Houston has an established market and extensive infrastructure for conventionally produced hydrogen. The consumed hydrogen is produced within many facilities (48) using processes such as steam-methane-reforming (SMR) and auto-thermal-reforming (ATR) processes (grey hydrogen). More than five Mt of CO<sub>2</sub> per ton of hydrogen is emitted in the process, contributing to Texas's leading CO<sub>2</sub> emissions. A network of hydrogen pipelines (900 km) and large-scale salt cavern storage assists in balancing this system while providing hydrogen to remote users (CHF, 2021).

The US Gulf Coast also has an existing network of hydrogen consuming facilities, with the main consumers being the refining and chemicals industries. Within the Gulf Coast, Texas and Louisiana combined provide half of total US refining capacity and a third of ammonia capacity.

## **1.2. The role of low carbon hydrogen in energy transition**

Decarbonisation of energy end uses is required to achieve significant GHG reductions. The greatest challenges will be addressed through electrification, low or carbon free fuels and the direct uses of renewables. Despite the rapidly increasing deployment of renewables in the power sector, industrial processes and domestic heating remain heavily reliant on fossil gas and other hydrocarbons.

Hydrogen from electrolysis was first discovered in the 1800s and has been continuously used since, with a recent revolution around "green" electrolysis, or green hydrogen, occurring where the provided energy is from renewable energy sources such as wind, solar and geothermal. The facilities used to produce green hydrogen incorporate several distinct technologies depending on supply chains and source materials. They also incorporate balance of plant (BoP) equipment common to other industries which are increasingly being optimised for green hydrogen applications. These are described in further detail in Appendix A.

Green hydrogen is not the only use of electrolysis. Electrolytic hydrogen is unique in producing pure (over 99.9%), dry and carbon-free hydrogen from electricity, but source of electricity can vary. Nuclear power is viewed as a potential carbon-free electricity source (often called "pink hydrogen"), while electricity from a grid (often called "yellow hydrogen") can be carbon-free if coming from grids highly dependent on nuclear or hydroelectric. With the recent focus of the Inflation Reduction Act (IRA) in the US on zero-carbon hydrogen, electricity sources other than renewables may arise as potential carbon-free hydrogen sources in the near and longer term.

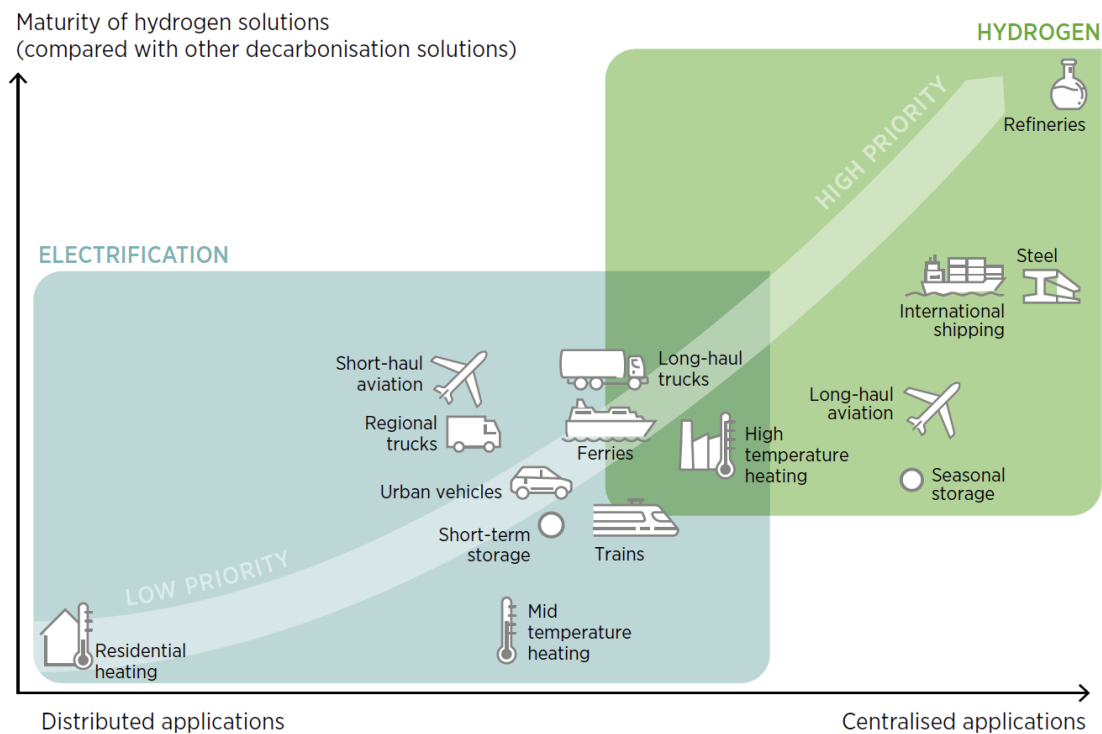
In contrast, hydrogen production methods such as grey, blue (grey with carbon capture), or turquoise are dependent on combustible fuel sources – generally fossil fuels. Other conventional and less-carbon intensive methods for producing hydrogen involve hydrocarbon value chains are shown in Figure 1, though this list should not be considered exhaustive.

Figure 1: Alternate methods of hydrogen production



Production of green hydrogen is considered an essential element for the decarbonization transition due to its use as a valuable fuel in the transportation, chemical, and industrial spaces. Green hydrogen is critical to decarbonising these sectors. This includes the direct use of clean hydrogen (predominantly green hydrogen) along with synthetic fuels (green ammonia and methanol) and clean hydrogen-based feedstock. The expected role and relative maturity of hydrogen in these applications is shown in **Figure 2**.

Figure 2: Profile of hydrogen applications



Source: (IRENA, 2022)

According to IRENA, to make this contribution the cumulative installed capacity needs to grow to 350 GW by 2030. Europe made a clear commitment to green hydrogen (ECHA, 2022) as outlined in its Hydrogen strategy and RePower EU plan. However, the current deployment and pace of growth of green hydrogen is limited, with 0.5 GW of electrolyzers installed worldwide in 2021 (IRENA, 2022).

With both O&G majors and chemical producers pledging to transition to net zero, high emission levels of grey hydrogen provide an opportunity to decarbonize, through two potential technologies: blue and green hydrogen. The Houston hub has advantages to succeed in both, with most experts believing green and blue hydrogen will co-exist on the US market in the mid-term.

While blue hydrogen is currently cheaper than green hydrogen, their costs are expected to converge as electrolyzers and renewable energy become cheaper and natural gas more expensive. Experts agree this will happen in the US, although opinions differ on timing:

- IRENA, quoting BloombergNEF, suggests 2028 (IRENA, 2022b).
- Recent reports from CHF contain a range of estimates between 2033 and 2047 (CHF, 2022).

### 1.3. Motivating policy

The important role of hydrogen hubs in accelerating deployment has been recognized by governments within the US. These programs are a substantial catalyst for the formation and development of hydrogen hubs within the US. The US has set a goal of achieving or exceeding the clean hydrogen production cost targets for electrolyzers to less than \$US 2 / kg H<sub>2</sub> by 2026 and the USDOE has established the Hydrogen Shot™ goal of \$US 1 / kg H<sub>2</sub> of clean hydrogen in one decade.

The US government enabled the development of regional clean hydrogen hubs through the passing of the Infrastructure Investment and Jobs Act (IIJA) in late 2021 (also known as the Bipartisan Infrastructure Law). This included funding for:

- Regional clean hydrogen hubs (\$US 8 billion)
- Hydrogen manufacturing and recycling initiative (\$US 500 million)
- Clean Hydrogen electrolysis program (\$US 1 billion) – of primary interest to this report

In anticipation of the implementation of these programs, the Department of Energy (DOE) has been collecting input as exemplified by a recent request for information on Clean Hydrogen Manufacturing, Recycling, and Electrolysis (DOE, 2022). This seeks input on practical and innovative approaches to increase the reuse and recycling of clean hydrogen technologies by:

- Increasing the efficiency and cost-effectiveness of raw material recovery from clean hydrogen technology components and systems, including enabling technologies such as electrolyzers and fuel cells.
- Minimizing environmental impacts from recovery and disposal processes.
- Addressing any barriers to research, development, demonstration, and commercialization of technologies and processes for the disassembly and recycling of devices used in the clean hydrogen value chain.
- Developing alternative materials, designs, manufacturing processes and other aspects of clean hydrogen technologies.
- Developing alternative disassembly and resource recovery processes enabling efficient, cost-effective, and environmentally responsible disassembly of, and resource recovery from, clean hydrogen technologies.
- Developing strategies to increase consumer acceptance of, and participation in, the recycling of fuel cells.

CHF submitted a response to information request in March 2021, establishing awareness of Houston's advantages and intent to develop a hydrogen electrolysis manufacturing center.

The USDOE provided a Notice of Intent on the regional clean hydrogen hub program in June 2022 including a schedule for the application and expansion of several funded hubs from four to between 6-10. No similar update has been released for the Clean Hydrogen Electrolysis Program although an expected application opening date in the fourth quarter of 2022 has been indicated. (Clean Hydrogen, 2022).

Clean hydrogen has recently received a massive boost from the Inflation Reduction Act of 2022 (IRA), as is discussed in greater detail in Section 5.4.2. The IRA includes approximately \$US 369 billion in energy security and climate change investments including tax credits for producers of low-carbon hydrogen. The low-carbon-hydrogen provisions are also technology neutral, meaning the net result is a reduction of the cost of low carbon hydrogen making it competitive and, in many cases, cheaper than fossil alternatives (Zorpette, 2022).

#### **1.4. Exclusions and limitations**

The scope and structure of this report results in a focus on integrated electrolyzer manufacturing within a Houston Hub. The scope of the assessment is limited by the exclusions, assumptions and limitations noted within this report. The following aspects have been excluded:

- Development of Houston as a hydrogen hub, as covered in related publication (CHF, 2022) including hydrogen production, storage, integration into transport and industry and export.
- Description and comparison to hydrogen originating from hydrocarbon or organic value chains.
- Other energy transition technologies associated with the energy transition and supportive of low carbon hydrogen generation (ex. Carbon Capture and sequestration).

## 2. Stakeholder identification and engagement

A variety of stakeholders were consulted in this assessment. Stakeholders were identified and organized according to roles in electrolyzer market development. Key drivers determined through the market and technology review were further tested and expanded through the stakeholder engagement process. Lastly, the suggested actions proposed were frequently indicated as critical to success by stakeholders.

The stakeholders included in this report were identified using a survey and expert input. The stakeholders provide a primary basis for the analysis and recommendations based on insights and experiences collected through engagement.

### 2.1. Stakeholder definitions

Stakeholders have been defined according to the following general categories:

- Existing businesses with relevance to the supply chain ('suppliers').
- Companies integrating the components for large-scale electrolyser systems ('integrators').
- Public authorities, institutions and other groups creating supportive conditions ('enablers').

Not all stakeholders fit into a defined role, so they have been defined broadly at the initial level and in terms of their supply chain role(s) at the secondary level. This is broadly consistent with other analysis completed, as summarized in **Table 1**.

**Table 1: Roles in the electrolyzer production chain**

Stakeholder role	Supply chain role	Description
Suppliers	Stack components	Provide the separate components of the electrolysis stack such as membranes, electrodes, catalysts, coatings, sheeting, and bipolar plates.
	BOP components	Provide the additional technologies and components converging at the system integration stage including power electronics, controls, cooling, water purification, gas purification and compression.
Integrators	Stack and System integration	Assemble the electrolyser from the components. Assemble complete electrolysis installations to a ready to operate status.
	EPC	Engineer, procure, and construct large electrolyzer systems (without owning technology).
Enablers	Academic, Technology, and Training Institutes	Education and training for human capital including new entrants and skills transfer from related industries.
	Research	Research and development of materials and technologies.
	Operators	Expected core owner operators of large electrolyser systems such as industrial gas and energy companies.
	Investors	Provide capital and business guidance.

## 2.2. Main value chain participants













The electrolyzer market is still forming, with participating companies exhibiting typical patterns of frequent mergers, acquisitions, spin-offs and initial public offerings (IPO). The level of segmentation remains challenging but the following major “origination sources” for incumbents are:

- Subsidiaries/JVs of big manufacturing conglomerates with broad portfolios
  - Notable examples include John Cockerill, Nucera by ThyssenKrupp as well as Siemens Energy.
  - Given the financial and distribution power of parents, this category is dominating market share as of 2021 (roughly a third of global market for John Cockerill).
- Subsidiaries/JVs of medium-sized specialized players
  - NEL (Norway based), which leveraged its historical electrolyzer expertise.
  - Longi (China based), specializing in solar energy.
  - Elogen (France based) whose parent GTT is focused on LNG containment systems.
- Hydrogen pure play “start ups”
  - Notable examples are ITM, McPhy and Sunfire.
  - Have a small market share.
  - Have established capacities and ambitious plans for its expansion backed by equity raised from financial investors.

Given significant technological similarities, most participants are active in electrolyzers and fuel cells. Within the electrolyzer market these companies gain 15% of revenue from service and maintenance of installed fleets. Integration across the supply chain is limited to companies historically present in BoP and now expanding to stack assembly (ex. Siemens). According to interviews with the market participants, manufacturers tend to focus on assembly while outsourcing components.

Figure 3 provides an example of stakeholder companies identified through assessment of a relevant supply chain vertical.

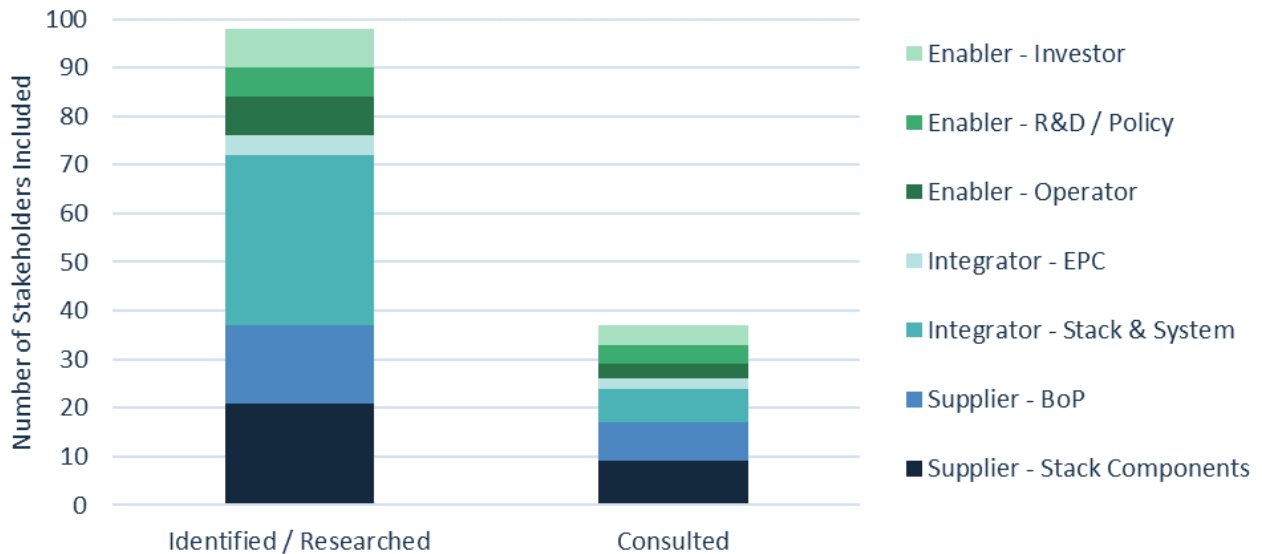
Figure 3: Selected PEM supply chain participants

Stack Components	PEM Stack integration	Balance of the plant components	System integration
<p><b>PFSA</b></p> 		<p><b>Power supply</b></p> 	
<p><b>Catalysts and coating providers</b></p> 		<p><b>Thermal management</b></p> 	
<p><b>Porous Transport Layer (GDL)</b></p> 		<p><b>Fluid&amp;gas management</b></p> 	
<p><b>Bipolar &amp; End Plates</b></p> 		<p><b>H2 storage</b></p> 	
<p><b>Seals &amp; gaskets</b></p> 		<p><b>H2 compression</b></p> 	

### 2.3. Consultation summary

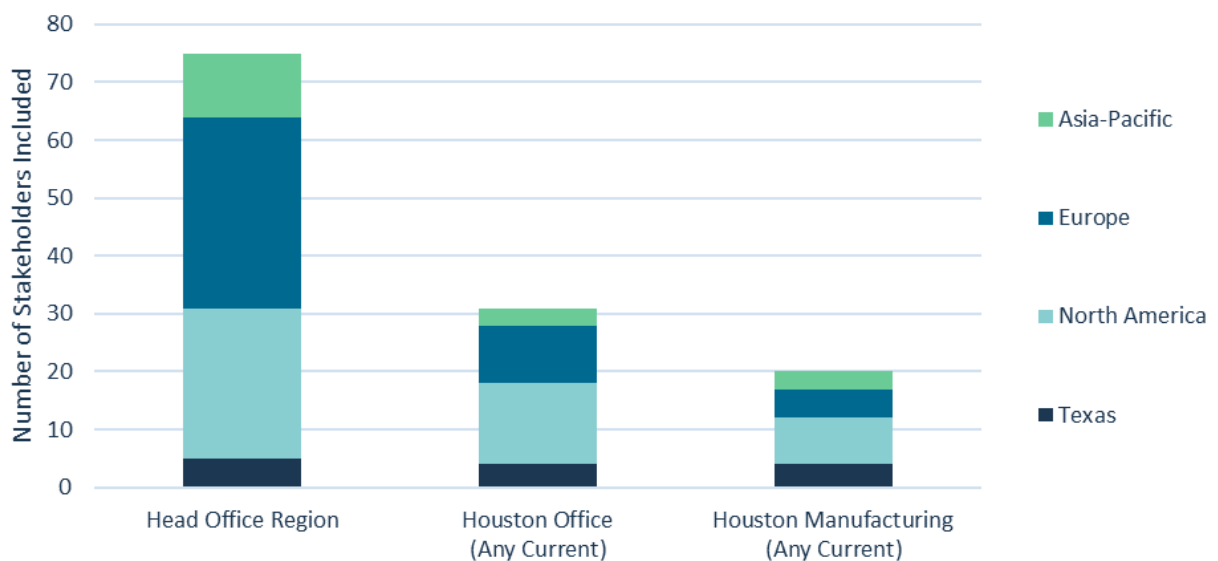
The study considered approximately 100 different stakeholders, of which over 30% were interviewed as shown in **Figure 4**. An overall focus was placed on the supplier and integrator roles.

**Figure 4: Stakeholders evaluated by role**



The selection also considered the current location of stakeholder operations, as shown in **Figure 5**. This figure only includes the supplier and integrator roles.

**Figure 5: Operational profile for included stakeholders**



*Note: # by location of Head Office (Suppliers and Integrators Only)*

**Figure 5** shows a significant number of stakeholders have manufacturing or related offices located in Houston. This figure shows a good proportion of included companies are based elsewhere globally while having a Houston office, and to a lesser degree companies based elsewhere have manufacturing in Houston.

Many of these companies produce a variety of products and services including those within the electrolyzer value chain. Where Houston office and manufacturing is indicated, it relates to any activity and not necessarily electrolyzer products. The differentiation between companies already present and those needing to establish a new presence is used later within the analysis.

This figure does not indicate overall proportions of related global companies who are also located in Houston as related Houston companies were included preferentially while global companies were not included exhaustively. For example, only a limited number of the Alkaline electrolyzer producers located in Asia were researched and none were consulted.

## 2.4. Stakeholder highlights

The following section outlines the key messages provided by the stakeholders formally engaged through interviews, observations within interactive workshops and conferences during the study period.

From interviews with equipment manufacturing stakeholders throughout the engagement, common key insights were established and were then confirmed in retroactive feedback sessions. These findings paint a picture of an industry in the process of transition. In past years, low-carbon hydrogen equipment manufacturers faced technical and economic issues – how to develop a marketplace when their product carried a price premium for hydrogen production. Their product has now overcome many of these technical and economic issues but is dealing with logistical ones – how to expand rapidly to meet demand, how to gain access to capital, and how to build a supply chain for critical components and materials.

These insights are described in **Table 2**. In section 3 we begin to weigh these insights to provide a closer look at how manufacturers view these issues in relation to one another.

**Table 2: Key stakeholder messages**

Category	Key Insights
Demand base	<ul style="list-style-type: none"> <li>• The primary consideration for most manufacturers in deciding where to develop manufacturing is where the most demand is occurring – if Houston had a significant part of their product demand, they would consider it a prime location.</li> <li>• Smaller manufacturers hoped to take advantage of Houston’s existing manufacturing base to potentially repurpose existing facilities.</li> <li>• Larger manufacturers hoped to expand into potential manufacturing in Houston through an acquisition.</li> <li>• Houston already has potential demand sources from industry and refining in Texas and the Gulf Coast area.</li> <li>• Hydrogen export shipping in Corpus Christi was cited as another potential demand source.</li> </ul>
Incentives	<ul style="list-style-type: none"> <li>• Behind demand base, incentives were a key concern for all equipment manufacturers.</li> <li>• Texas and Houston were considered very business-friendly; manufacturers were interested in an assessment of what bureaucratic hurdles they would face (or would be avoided) by moving to Houston, and what potential tax, land, or other incentives they might receive compared to competitive locales.</li> </ul>



Category	Key Insights
Hub development	<ul style="list-style-type: none"> <li>Manufacturers large and small are interested in where DOE's hydrogen hubs in the Build Back Better bill will eventually be located. Many are holding off on major decisions until confirmation of where government funding – and anticipated equipment demand – is going.</li> <li>Texas in general is viewed as a prime candidate for low-cost renewables, making green hydrogen seem natural. However, Houston is seen as less a renewable hotspot than West Texas or other zones – green hydrogen is usually manufactured where renewables are based.</li> <li>Houston/Gulf Coast were called out as more of a natural home for blue hydrogen, and some concerns over which manufacturing stream Houston would favor. Would Houston hub focus on both blue and green?</li> </ul>
Workforce	<ul style="list-style-type: none"> <li>Houston employees in O&amp;G bring skills and experience useful for hydrogen manufacturing in both the engineering and factory labor skillsets.</li> <li>Houston is seen as having access to a highly skilled workforce in the energy space – US's second largest manufacturing workforce.</li> <li>Key types of employee backgrounds: manufacturing experience, automation, metal machining/engineering, chemical engineering.</li> <li>Some concern O&amp;G can outcompete a nascent hydrogen industry for skilled labor.</li> </ul>
Texas O&G background	<ul style="list-style-type: none"> <li>Texas's/Houston's background in O&amp;G manufacturing is generally seen as a positive – many companies in hydrogen BoP supply chain already in Texas/Houston with a good industrial base existing.</li> <li>At same time, O&amp;G industry has greater resources to pull on BoP suppliers (API-certified equipment is same as hydrogen and sells for 4x the price) and could throttle hydrogen supply chain.</li> <li>Some worry Texas/Houston might favor O&amp;G politically and may push out hydrogen if it offers significant competition.</li> </ul>
Research and development	<ul style="list-style-type: none"> <li>University of Texas at Austin (UT), University of Houston (UH) seen as world class research and development facilities and potential partners.</li> <li>Many small and medium manufacturers are interested in developing research hubs to share resources, collaborate and combine to reduce costs.</li> <li>These groups have traditionally looked to NREL and DOE (Hydrogen and Fuel Cell Technologies Office in particular) as prime partners and funders for research, and the location of their future research offices and projects is a prime consideration in manufacturing expansion plans.</li> <li>Large manufacturers generally handle R&amp;D in-house and are less interested in group collaboration. Though collaboration does happen, many larger interviewees expressed preference for one-on-one relationships rather than research consortiums.</li> </ul>

Category	Key Insights
Testing and standards	<ul style="list-style-type: none"> <li>• If hydrogen testing and standards development were happening in Houston, it would make the city more attractive for manufacturing.</li> <li>• Hope from manufacturers across supply chains for a system to certify clean hydrogen's origin, which they believe will increase demand and price point for it.</li> <li>• Similar to R&amp;D, smaller companies are interested in whether DOE or others will pivot towards developing standards and testing for hydrogen parts to make the supply chain more fungible (using a new supplier for a gasket, electrode, or other part is difficult, as substantial internal testing must happen and may require redesigns).</li> <li>• Larger manufacturers frequently use vertically integrated supply chains and source parts from in-house – standards are not as much a concern.</li> </ul>
Capital access	<ul style="list-style-type: none"> <li>• Getting access to capital is not easy for companies being asked to rapidly expand to meet demand for green hydrogen equipment – companies expose themselves to ruin if demand does not rapidly materialize.</li> <li>• For many smaller manufacturing companies, rapid expansion requires equity funding – to expand and meet demand they must cede control of the company, which is a very difficult choice.</li> <li>• Low-cost financing or demand guarantees would help companies feel secure in rapid expansion – a few months delay in demand can mean disaster.</li> <li>• Part manufacturers (BoP, membranes, bipolar plates, and more) have more difficult time securing capital, and are expanding at a slower rate than electrolyzer manufacturers – this is creating a potential supply chain imbalance.</li> </ul>
Logistics	<ul style="list-style-type: none"> <li>• Shipping challenges are plaguing manufacturers across the spectrum with difficulties in shipping parts, or getting parts shipped to them.</li> <li>• Smaller companies are generally feeling this strain more than larger ones.</li> <li>• As covered in “Capital Access,” parts manufacturers are not expanding as rapidly as electrolyzer manufacturers or system integrators. This is leading to long lead times (in some cases more than a year) for key equipment and parts.</li> <li>• Key parts called out were power electronics, transformers/rectifiers, compressors, metal presses, pressure vessels, and hydrogen dryer units with more issues arising frequently.</li> <li>• Electrodes and membranes for electrolyzers are often manufactured in Europe; not only are lead times getting longer, but manufacturers worry about meeting “Made in USA” requirements when they cannot find required components made in the USA.</li> </ul>
Materials	<ul style="list-style-type: none"> <li>• Material requirements vary between technologies, but key materials becoming more expensive and difficult to obtain were platinum, iridium, nickel and carbon fiber (for storage vessels).</li> </ul>

### 3. Current strengths

Houston's attributes provide a strong foundation for hub development as described within this section.

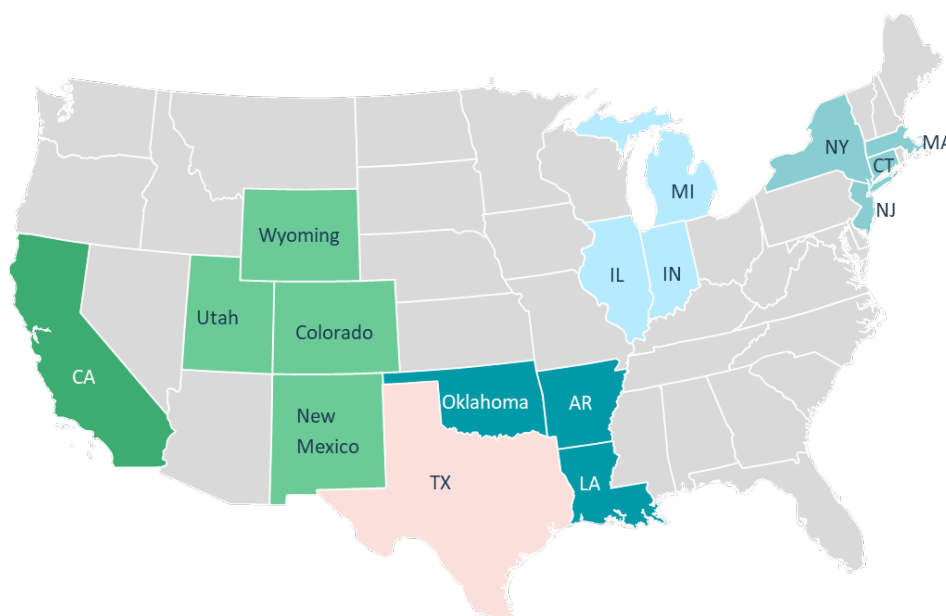
#### 3.1. Overall competitive position amongst hubs

A comparative assessment is useful for providing an objective view of the strengths and weaknesses of Houston as a potential center for hydrogen electrolyser equipment manufacturing. This section outlines and compares several proposed hubs to Houston.

Several parties have submitted information responses to the DOE's Regional Clean Hydrogen Hubs Implementation Strategy, which aims to develop at least four hubs. As shown in Figure 6, this includes:

- Southern California (HyDeal LA)
- Illinois/Indiana/Michigan (Midwestern Hydrogen Partnership)
- New York/New Jersey/Massachusetts/Connecticut
- Louisiana/Oklahoma/Arkansas (HALO Hydrogen Hub)
- Colorado/New Mexico/Utah/Wyoming (Western Inter-States Hydrogen Hub)

**Figure 6: Examples of US hydrogen hubs**



*Source: Publicly available submissions to US Department of Energy*

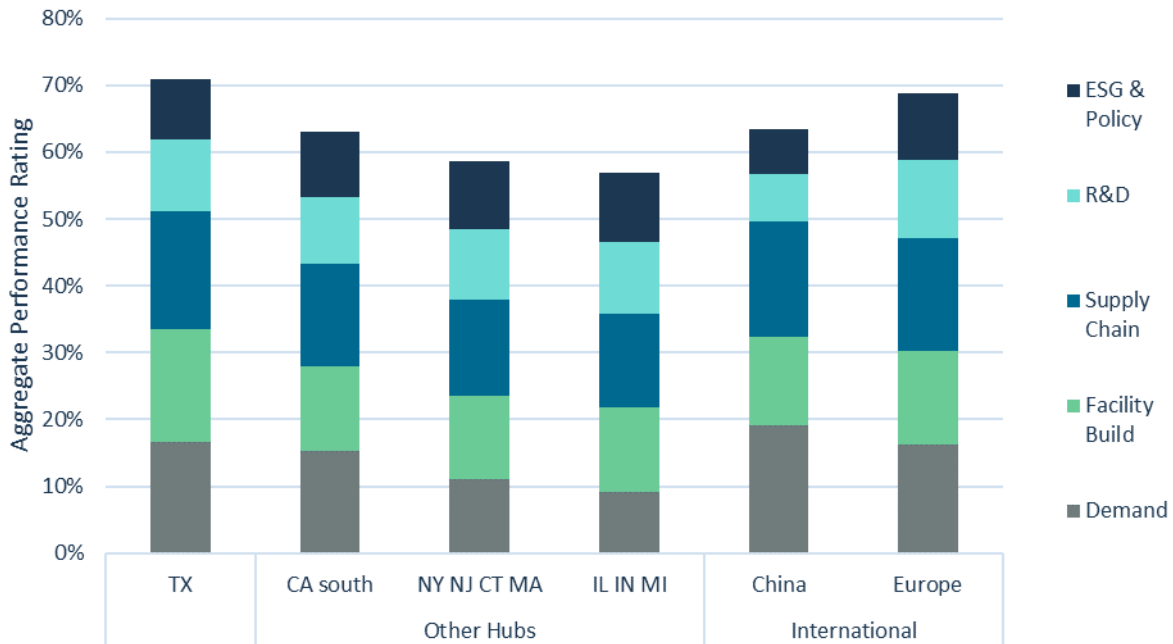
A multi-criteria assessment methodology was used for the comparison of these leading hubs. The methodology applied within the assessment is provided in **Appendix B - Multi-Criteria Analysis methodology**.

For the comparison, the USA hubs with similar scale of economy and workforce were chosen, namely:

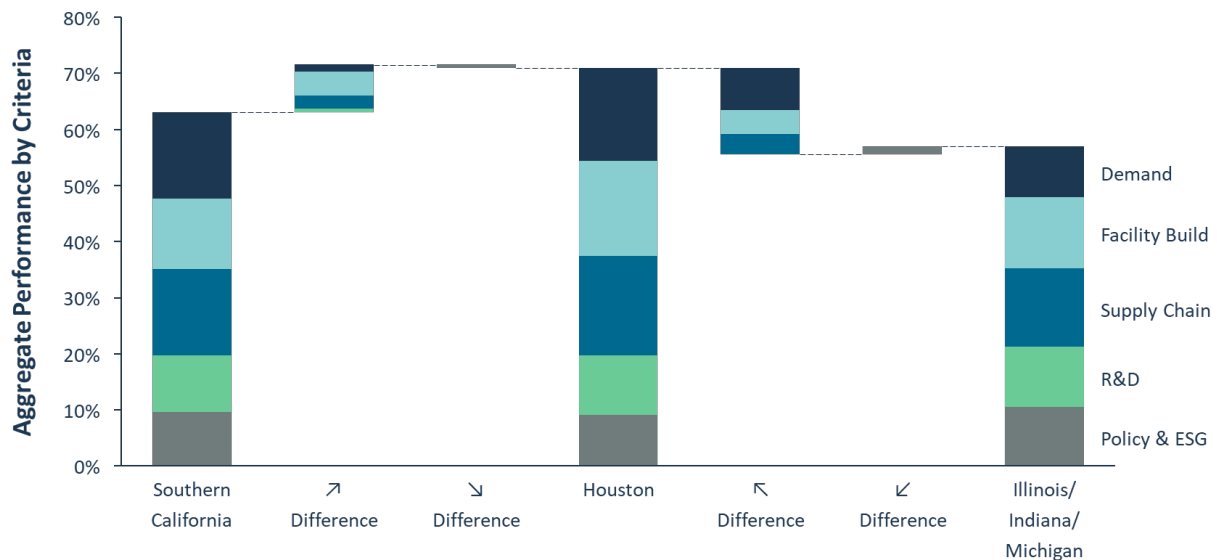
- Southern California (HyDeal LA)
- Illinois/Indiana/Michigan (Midwestern Hydrogen Partnership)
- New York/New Jersey/Massachusetts/Connecticut
- Hypothetical hubs located in China and Europe

The aggregated performance of these hubs is shown in Figure 7. As shown, the overall performance of Texas exceeds the other two leading hub candidates. Proposed locations within Europe, such as the Netherlands, are most comparable in overall strength to Texas.

**Figure 7: Aggregate performance of Texas hub compared to other us and international locations**

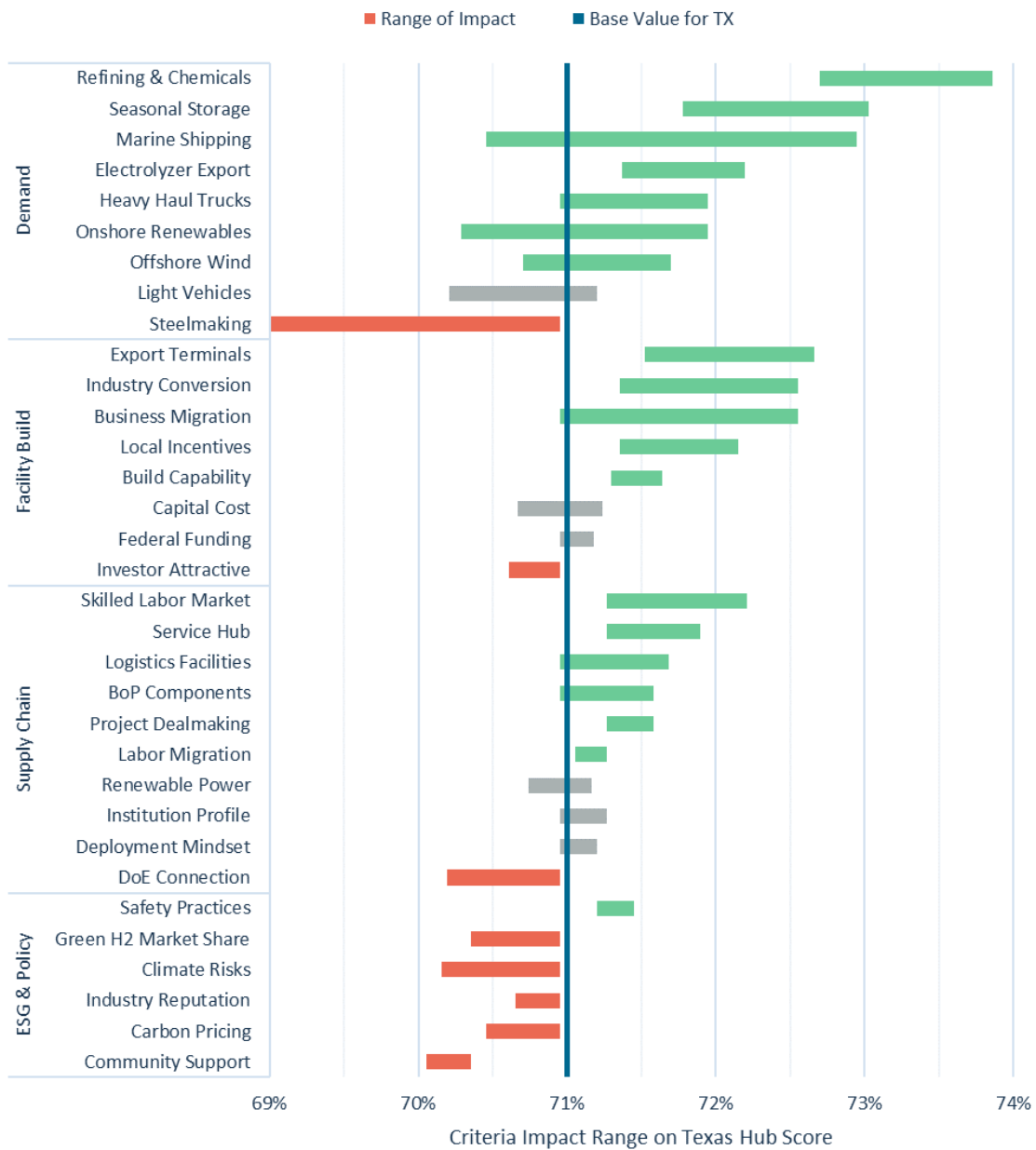


**Figure 8: Aggregate performance comparison between Houston and other major USA hubs**



The compared aggregated performance of Texas compared to other selected hubs is shown within Figure 8. As shown in Figure 9 below, the key differentiating factors for Houston include a combination of unique attributes combining to produce overall advantages for Houston.

Figure 9: Differentiating criteria for Houston compared to other us hubs



The key areas of advantage within the Houston hub are:

- Increased expected demand driven by:
  - Refining and chemicals applications (both for domestic and export markets)
  - Seasonal energy storage for “walled garden” of Texas grid
- Enhanced ability to establish facilities driven by
  - Business friendly culture and incentives
  - Existing facilities readily convertible to electrolyser production and distribution
- Effective supply chains with accessible supplies for BoP components and services

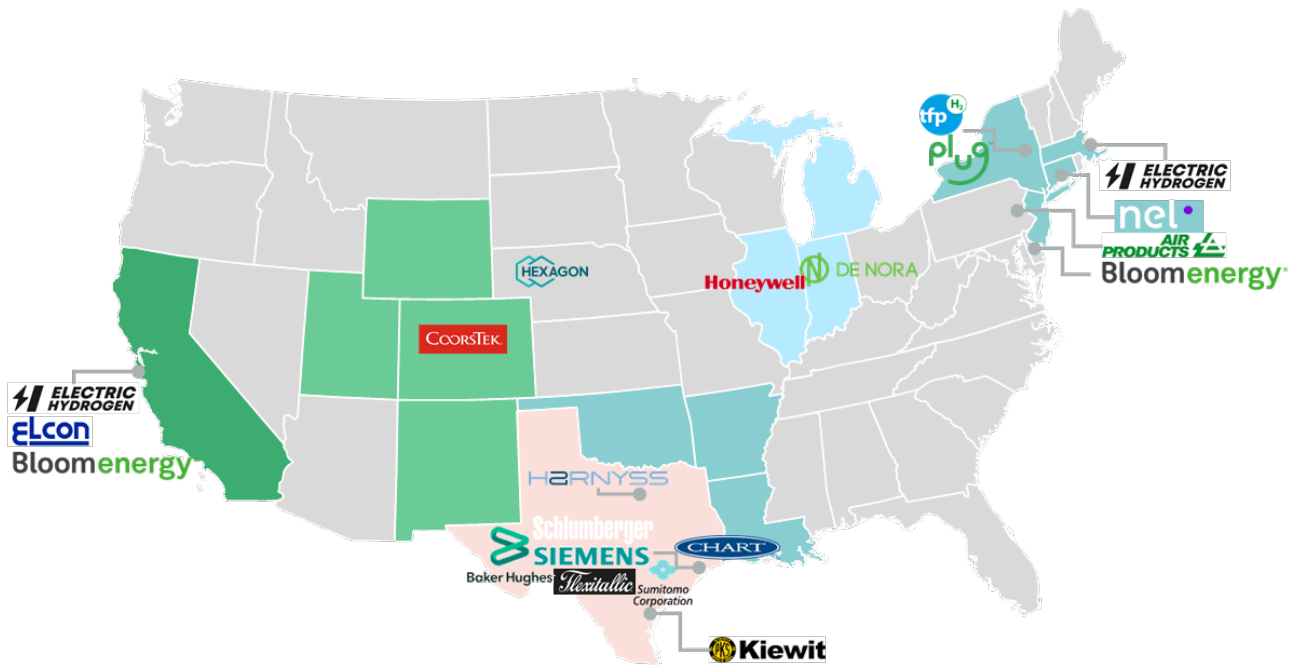
There are criteria where Houston lags which may still be addressed with cooperation of regulators, local business and the public. Many are rooted in the Houston hydrocarbon legacy, which historically features low level of general community support and has a cyclical demand for labour driven by fluctuating energy prices.

### 3.2. Willingness of companies to relocate

The key aspect explored within the stakeholder discussions was their willingness to build and/or relocate portions of their business within Houston. This considered the value chains associated with manufacturing of stack and BoP components as well as the integration of electrolyzer stacks and overall systems.

Most of the existing facilities and announced expansions are in the US northeast. Nel, which plans to expand its facilities in the USA up to 4 GW, did not publicly announce a specific location (it has small 50 MW plant in Wallingford).

Figure 10: Map of selected US manufacturing facilities, component providers and announced expansions



Through discussions and direct questions, the current willingness of stakeholders was gauged according to the scale provided in Table 3. The consulted stakeholders included those not currently present in the Houston market (Entrants) and those present (Incumbents). Only the supplier and integrator stakeholder categories are included in this section.

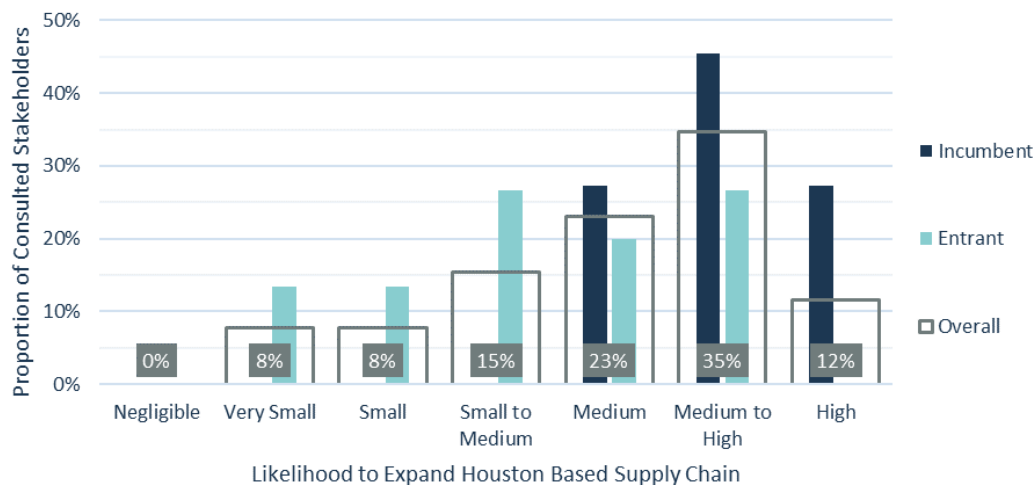
Table 3: Stakeholder likelihood to expand Houston based supply chain

Score		Entrant	Incumbent
Negligible	1	Not in market, excluded from future presence.	Withdrawing / strategically reducing operations in market without prospect of reversal.
Very Small	2	Not in market, no firm indication or intention they will enter.	Minor presence in market, static and growth focus elsewhere. Products entirely imported without local inputs.
Small	3	Not in market, will limit future increases to product marketing functions.	Established presence in market with some interest in directing growth. Products mostly imported with some local inputs.
Small to Medium	4	Not in market, observing market and will establish presence as market develops to partially meet local demand but supplement with imports.	Established presence in market with some interest in directing growth. Products mostly imported with value add.

Score		Entrant	Incumbent
Medium	5	Not in market, observing market and will establish presence as market develops to meet local demand.	Dispersed operations including presence in market and some local manufacturing / assembly. Balanced investment.
Medium to High	6	Not in Houston but strongly interested, actively scouting for establishment of substantial proportion of capacity to meet global ambitions.	Strong manufacturing/ employment presence in area with intent to meet local / regional demand going forward, supported by capacity to expand.
High	7	In process of establishing, majority of international operations will be from new base in Houston.	Already manufacturing in area, will expand aggressively hold market and serve export markets.

The overall results and a further breakdown by current Houston market presence is shown in Figure 11. This indicates a majority have an intent to expand in the Houston market, with the greatest proportion having a strong interest in establishing and expanding their operations. There is some divergence in results based on current presence, as incumbents are strongly motivated to build capacity in the market while potential entrants are more balanced in their intentions. There were no respondents unwilling to consider a manufacturing presence.

**Figure 11: Stakeholder likelihood to expand Houston based supply chain, by current Houston presence**

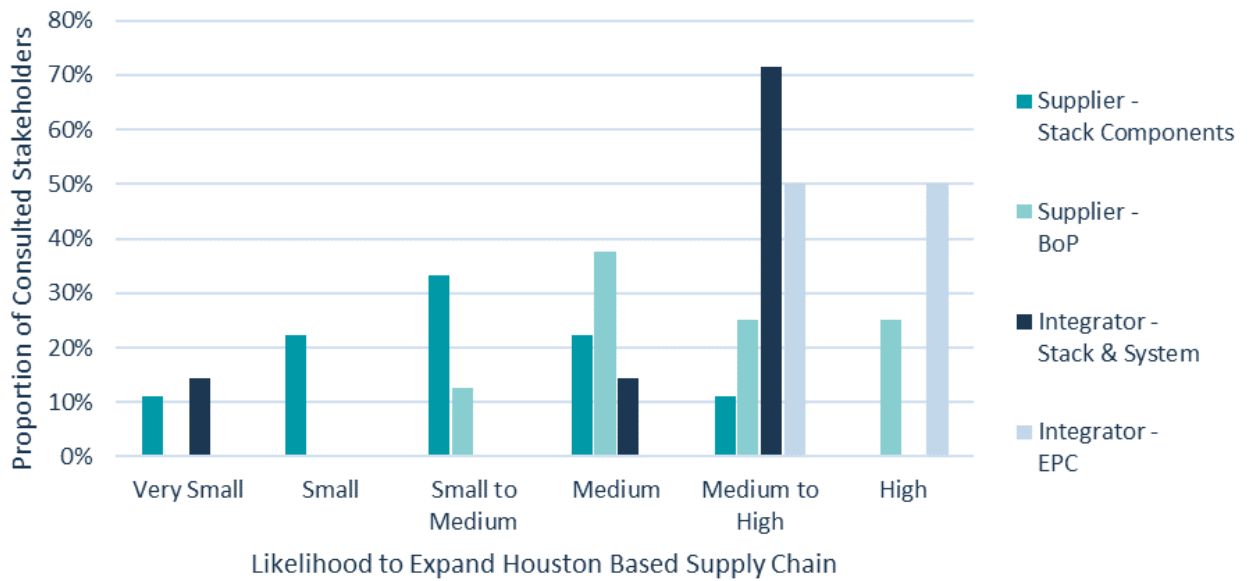


An additional perspective on likelihood to expand the Houston based supply chain is provided in Figure 12, which considers the stakeholder type. The results show distinct trends for different groups including:

- Stack component suppliers have the lowest current intention to establish manufacturing in Houston. Several stated they would limit future presence to marketing and importing, even as the market develops. All are located outside of Houston (with the majority based in Europe) and would be new entrants.
- BoP suppliers have a higher but overall medium intention to further establish or expand manufacturing in Houston. They are more willing to expand or establish operations in Houston to meet future demand, including export of products produced in Houston. The group is more varied in base of operations and current location of manufacturing.
- Stack and system integrators showed an elevated interest in establishing businesses in Houston to a promising market. In contrast with stack component suppliers, they are more open to establishing new operations even though all of those consulted would be entrants. The exception is one stakeholder that is not likely to pursue the North American market at all.

- EPC integrators that were included were already present in the Houston market and are strongly interested in continuing to expand operations to compete within the market.

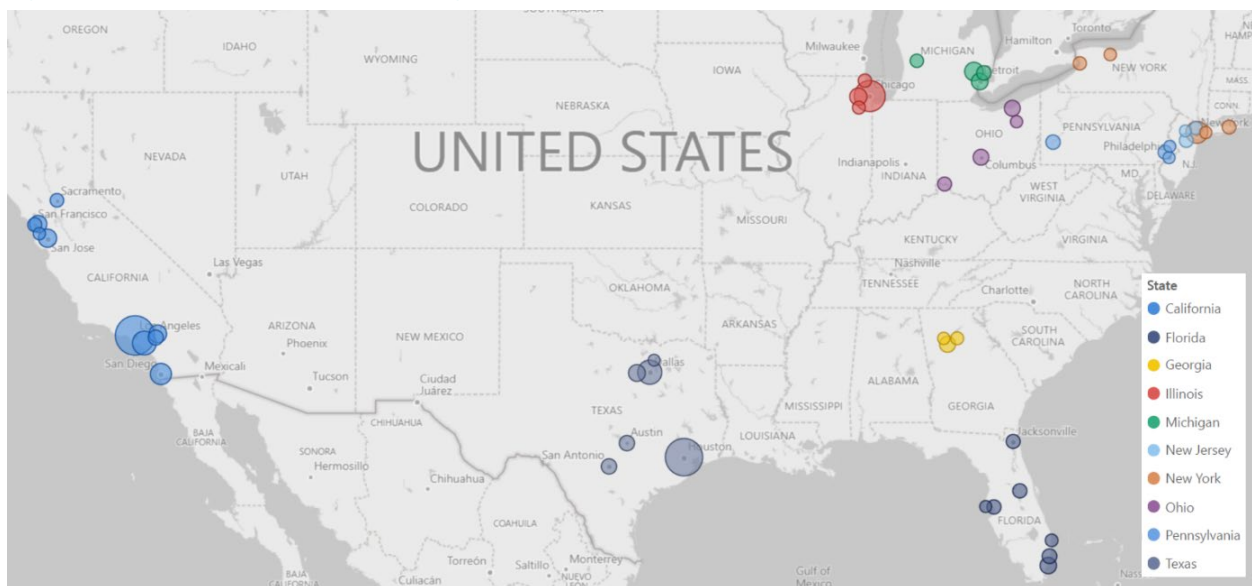
**Figure 12: Stakeholder likelihood to expand Houston based supply chain, by stakeholder type**



### 3.3. Available labour pool

The establishment of hubs is primarily motivated by the opportunity presented by and to a population and industrial base. A strong indicator both are present is a large available workforce. The available workforce can be compared through selection of relevant industry groups according to the North American Industry Classification System (NAICS) (US Census, 2021). The most relevant administrative boundary to use for identification and comparison is the county level. The bubble size represents the relative workforce size, by county. The top 50 counties across the 10 largest employment states are included in **Figure 13**.

**Figure 13: Counties within states with highest relevant workforce**





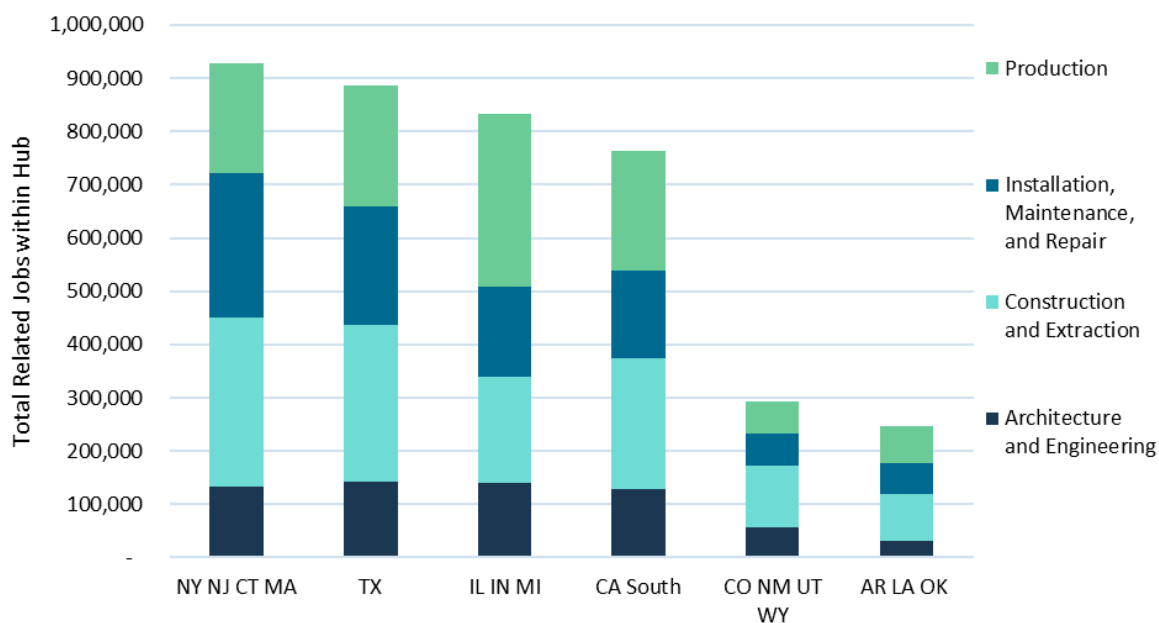
Several existing clusters with dominant centers can be seen in Figure 13. Within Texas, Houston (Harris County) represents the largest work force with smaller but still significant centers in Dallas-Fort Worth and Austin-San Antonio as potential satellite hubs.

Focusing on the workforce sectors that may directly contribute to the buildout of an electrolyzer manufacturing system, a similar pattern can be seen in

Figure 14. The overall values were determined through selection of relevant job titles within the Standard Occupation Classifications (Department of Labor, 2022).

Figure 14 shows the relative size of the workforce across relevant occupations in the currently defined hydrogen hubs. Note the Houston hub also includes adjacent cities and is defined as “TX” for clarity as shown in the following Figure 15.

**Figure 14: Available related workforce within proposed hubs**



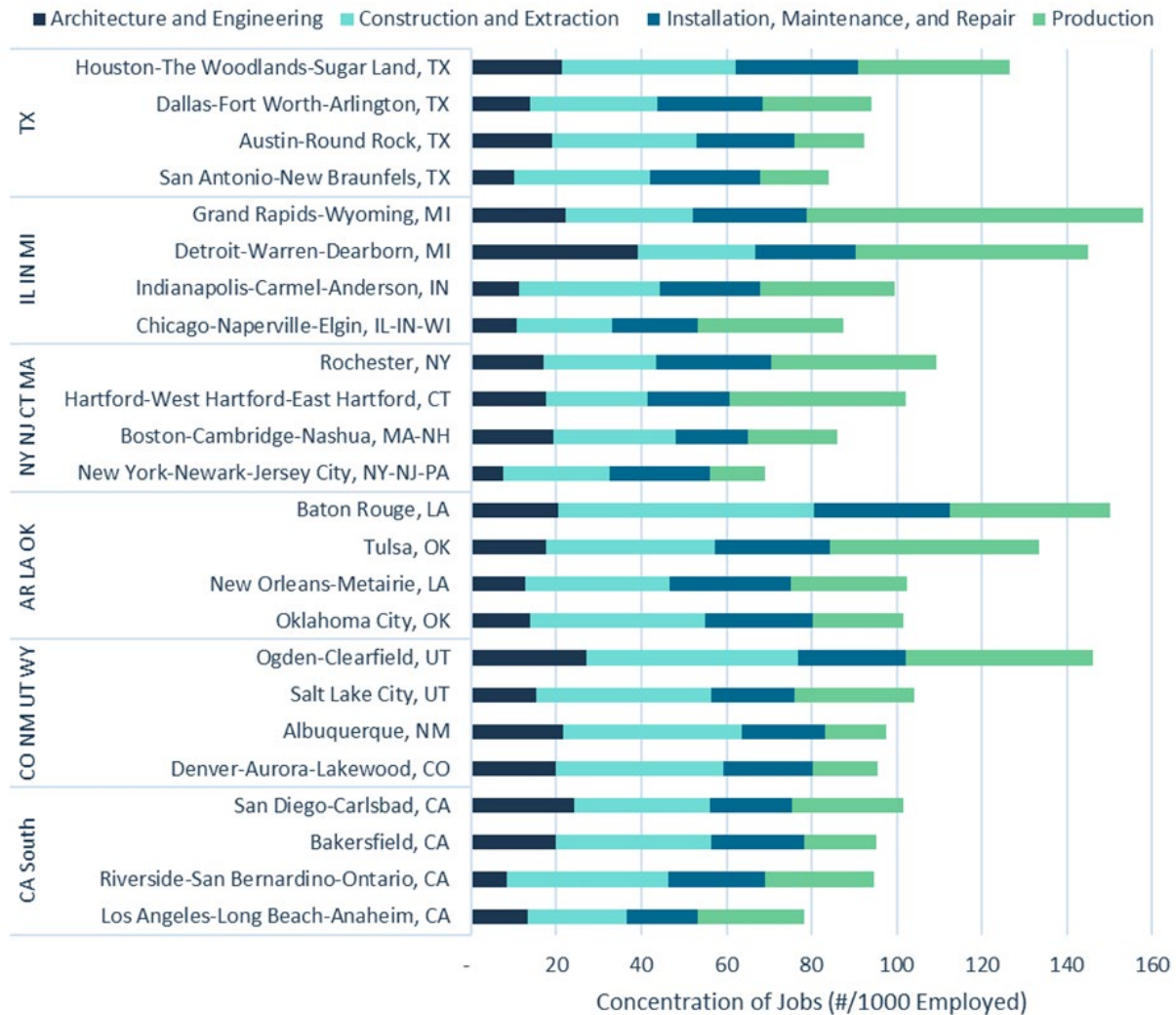
Source: (Department of Labor, 2022)

Figure 14 shows there is a similar workforce available between the four largest proposed hubs, although it takes a consolidation of several states to achieve this in all cases except southern California. The available workforce within the Louisiana/Oklahoma/Arkansas and Colorado/New Mexico/Utah/Wyoming hubs are dramatically smaller.

Figure 15 provides a perspective of the available workforce concentration within the main centers (greater metropolitan areas) in each proposed hub. Figure 15 shows:

- The highest overall workforce concentration is within the large centers in Michigan, driven by existing manufacturing industries. However, Grand Rapids-Wyoming and Detroit-Warren Dearborn have smaller overall workforces (22% and 70% of Houston, respectively).
- Large centers like New York-Newark-Jersey City and Los Angeles-Long Beach-Anaheim have large labor forces driven by the overall population, but a lower concentration of related labor.
- Houston-Woodlands-Sugar Land has a relatively large workforce concentration with a large and balanced proportion of available skillsets.

Figure 15: Related workforce concentration – greater metropolitan areas within hubs



Source: (Department of Labor, 2022)

In relation to parties that have submitted proposals for the DOE’s Regional Clean Hydrogen Hubs Implementation Strategy, there are both applicants with:

- Large, related markets and workforces including
  - Southern California (HyDeal LA)
  - Illinois/Indiana/Michigan (Midwestern Hydrogen Partnership)
  - New York/New Jersey/Massachusetts/Connecticut
- Limited markets and workforces including
  - Arkansas/ Louisiana/Oklahoma (HALO Hydrogen Hub)
  - Colorado/New Mexico/Utah/Wyoming (Western Inter-States Hydrogen Hub)

Access to a qualified workforce is a cornerstone of Houston’s attraction for hydrogen manufacturing – oil and gas sector employees have proven to be excellent at working in the hydrogen space at all levels of research and production. Training will still be necessary to ensure potential employees can move seamlessly into the hydrogen space.

## 4. Transitioning manufacturing and services base

Houston is known as the “Energy Capital of the World”, with 237,000 residents employed in the energy sector due to being an early O&G producer. When the Spindletop gusher occurred in 1900, Houston emerged as a local hub for many reasons (including early real estate tycoons giving O&G access to real estate), but also because it was an important nearby hub for telegraph and rail connections. Today, the Houston metro area is responsible for <1% of Texas O&G production and is the hub for production around Texas. Texas is the global or regional headquarters for 44 major O&G firms, including supermajors Shell, Chevron, and ExxonMobil and the headquarters of dozens of machine shops, service companies and industrial companies making tools and parts for the O&G industry. These players in the value chain come together as proximity is a powerful tool for individual and collective success (Gilmer, 2018). Economies of agglomeration occur when related industries pool together to share cost savings. Companies have easier trade lines, communications and relationships with each other by virtue of proximity, while outside companies are denied this competitive advantage (Gilmer, 2018). As clusters grow, a cycle is created, drawing in more companies. For other cities to break this pull and attract O&G headquarters, they must offer extreme incentives to overcome the lost advantage of basing in Houston.

Accelerating the energy transition towards hydrogen depends on elements listed below and described further within this section:

- Existing facilities to be retrofitted into hydrogen value chain manufacture
- Zones which are well suited for greenfield development
- Training programs to develop a qualified R&D, management, and manufacturing workforce at all levels
- A deployment-focused R&D system working with key national and international institutions (ex. NREL and DOE)
- Supporting policies and subsidies for qualifying hydrogen equipment manufacturing and production activities
- Local associations of manufacturers across the value chain to improve logistics connections and create a more robust chain for manufacturers to tap into

The O&G hub provides Houston a head start in becoming the same for hydrogen. The need raised by every equipment manufacturer during our interview was proximity to demand. Having access to an industry center is a definitive element in deciding locations for plants or headquarters:

- “We would never leave Denver for Houston – unless the majority of hydrogen business was happening in Houston.”
- “We would never leave Rotterdam for Houston – unless the majority of our work was happening in Houston.”

Attracting hydrogen equipment manufacturing requires a critical mass of companies. This may be small and seeded by existing industry initially but will accelerate at the speed of growth of the hydrogen industry as a whole.

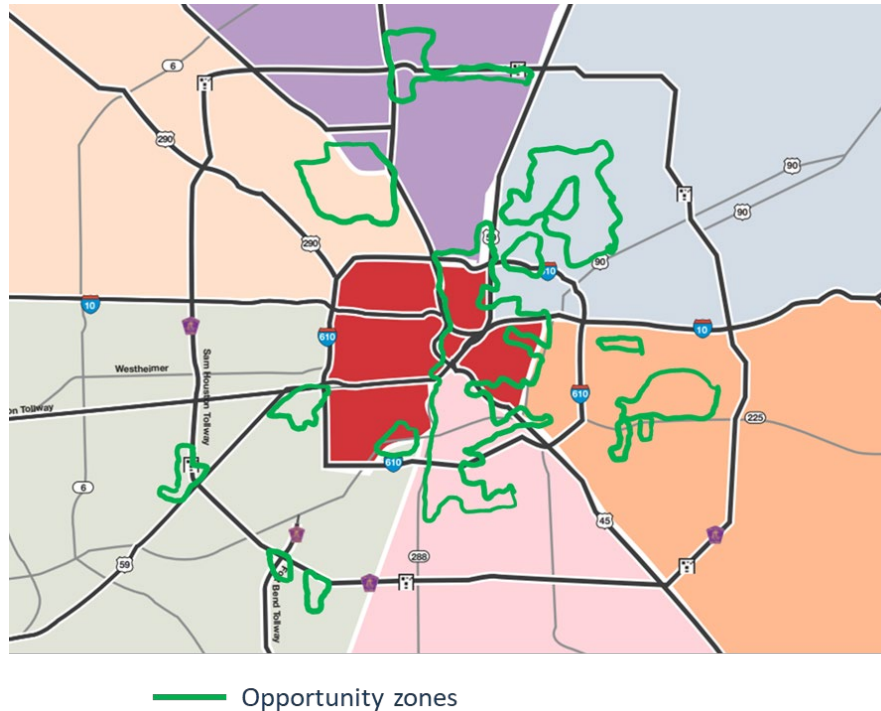
### 4.1. Establishing hydrogen manufacturing zones

Given the O&G industry is cyclical, existing facilities and infrastructure committed to the hydrocarbons value chain provide potential to be partially or fully tasked to the hydrogen value chain. This may require conversion to the manufacture of electrolyser component, modules and systems. During interviews with manufacturers, SMEs reported a preference for converting existing manufacturing facilities rather than performing greenfield builds (large corporations often planned to enter the area through an acquisition, though they had resources for greenfield builds).

Specialized zones dedicated to hydrogen equipment manufacture and logistics – electrolyzers, modular units, bipolar plates, etc – attract companies because they see the competitive advantage of locating close to their suppliers, off takers and even competitors. More companies increase the potential operational savings for established companies and the greater incentive for new companies to join.

More opportunities will become clear as this program progresses, but Houston's existing innovation and manufacturing centers will form initial points for concentrated hydrogen development and manufacturing in Houston. Initiating this in designated areas is easier and makes the program logistically manageable. Houston should take care these zones consider extending benefits to disadvantaged communities in the Houston area. The City of Houston has designated several Opportunity Zones, which provide tax incentives to tenants and spur local development, as shown in Figure 16.

**Figure 16: Potential opportunity zones in Houston**



Federal funding programs offer incentives for the inclusion of historically disadvantaged communities. These ties are easier to establish early than to build retroactively. Many disadvantaged communities also have greater access to warehouse and manufacturing space that can be retrofitted, offering advantages in multiple areas. Hydrogen-based manufacturing could utilize these developments to expand into these areas.

The CBD and Southwest zones may have significant opportunities for brownfield development, with large warehouse groups and unused industrial space which could be readily converted towards hydrogen electrolyzer and parts manufacturing. These zones have low rent prices, high land availability and lower current manufacturing operations. CBD also is closer to the river and industrial operations in the southeast region of Houston and can provide opportunities for local disadvantaged communities that may improve Houston's ability to meet Justice 40 guidelines for DOE hub funding. For greenfield development, the Northwest and Southeast areas of the city are seeing significant development of new industrial zones and infrastructure that could be utilized for new build hydrogen manufacturing, as shown in Figure 17.

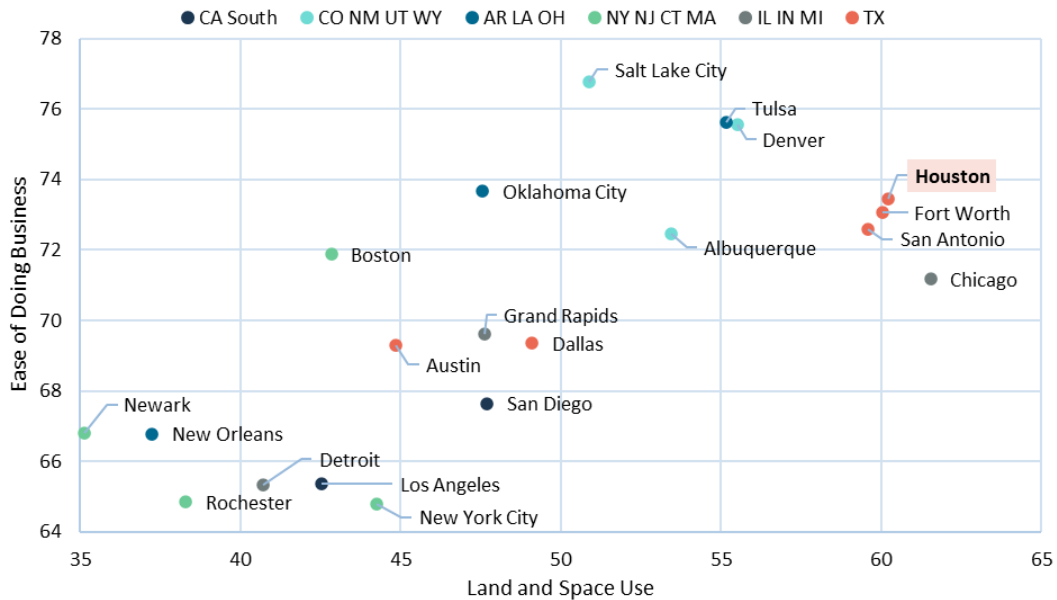
Figure 17: Opportunities for Greenfield development



#### 4.2. Perception challenges and policy needs

Houston and other major centers within the region have business-friendly attributes compared to other potential hubs regarding ease of establishing and running manufacturing facilities, as shown in Figure 18. Houston combines good access to suitable land and space combined with relative ease of doing business.

Figure 18: Land and space use compared to ease of doing business for cities in compared hubs, 2021



Source: (Arizona State University, 2021)

Cleantech projects, while beneficial to local communities, often meet resistance which may delay progress. While electrolyzer manufacturing has less potential opposition from communities, active outreach to communicate the economic, financial and fiscal benefits is necessary. This includes ongoing forums with local officials in affected and host communities to provide input, feedback and knowledge about hub projects and access to opportunities for community members.

North America is the global leader in producing start-ups with a perceived leadership by Silicon Valley, New York, and Boston. Founders are increasingly choosing to set up outside of these established systems, with declining share of investment in Silicon Valley as a key indicator. Houston is not perceived as a top global location for start-ups, but

is cited as an emerging ecosystem with high potential to be a global top performer in the coming years (Startup Genome, 2022a). Houston is similarly not in the top ranks of the cleantech start-up category with perceived weaknesses in (Startup Genome, 2022b):

- Performance in producing start-ups and maturing them to commercial enterprises
- Knowledge production including patent production
- Experience in start-up funding

Improving the perception would be useful in promoting the electrolyser hub, particularly as electrolyzer manufacturing is heavily populated by start-up firms. This requires efforts to address these issues and promote the image of regional cleantech.

The hub requires enabling policies which include a set of specific long- and short-term incentives, regulatory enablers and measurable goals to track progress. Specific incentives may include subsidies for electrolyzer equipment manufacturing, production activities and balanced regulations to ensure green hydrogen competitiveness compared to carbon capturing. With recent provisions from the IRA, many incentives for production are handled at a federal level, leaving Houston to focus on incentivizing sectors identified as pain points that are not getting the attention, investment or growth needed for overarching industry success. Broad business, investor and local community participants should be involved in the elaboration of policy instruments to ensure broad support as well as ownership for specific aspects of hub development.

### **4.3. Component standardization**

Standardization is a core concept of industrialization and the factory model. When interviewed, many small manufacturers cited the lack of standards for parts in the hydrogen parts industry as a major challenge. This included components from electrodes and membranes to valves and seals. This may be a smaller issue for large manufacturers with vertically integrated supply chains and internally set standards. Smaller manufacturers have difficulty sourcing new parts as they expand because parts varied from one manufacturer to the next.

As the industry scales, it looks more towards automation which is impossible if parts are not standardized within the same facility. It is more economic if standard parts and dimensions are used as the automation process itself can be duplicated between facilities, reducing costs and learning curves. The hydrogen industry has managed by utilizing the spare capacity of parts manufacturing from existing industries (eg., O&G), but these often require shifts to accommodate hydrogen, leaving them open to different part lines.

An example was provided by a small start-up manufacturer. When the capacity of their existing gasket manufacturer was inadequate, they attempted to source from a new one, but the parts were slightly different and required their units to be shifted. This is an untenable situation for any industry but is particularly difficult for an industry looking to scale as rapidly as hydrogen equipment manufacturing.

As the market scales up and pushes for more cost-efficient solutions, a level of standardization is inevitable.

Evidence for this is provided by the path of offshore oil equipment manufacturing, where standardized specifications and modular design became ubiquitous as a necessity for scaling and cost improvement.

Proprietary design and custom-built components may have worked in the nascent days of hydrogen, but as it moves towards process automation, standardization is necessary. Manufacturers are hesitant to take the first steps in establishing standards and certifications for systems and components for equipment interoperability. Objective leadership on standardization is typically provided by industry and government organizations. Industry organizations provide the pathway to establishing fit-for-purpose standards. This may also consider suitable existing standards and areas where new standards are required to ensure performance and economy within hydrogen systems.

#### 4.4. Energy service companies transitioning into hydrogen

“Reducing Scope 3 emissions is a goal we share with our customers as well as an enormous growth opportunity and a radical differentiator for Schlumberger, and we have already started to deploy Transition Technologies with customers around the world” (Schlumberger, 2022).

The worlds largest O&G service companies are in Houston forming an operations nerve centre. This includes the top 3 global companies who have made energy transition and hydrogen deployment commitments as described in **Table 4**.

**Table 4: Top global O&G service companies in Houston**

Company	Employees		Related commitments
	Global	Houston	
Schlumberger	>80,000	>10,000	Net-zero commitment inclusive of Scope 3 emissions made in 2021 — the majority of which occurs when deploying technology on customer projects. Expanding new energy partnerships through Schlumberger New Energy including green hydrogen. Builds upon fundamental strengths with ability to deploy at scale in any region in the world.
Baker Hughes	>50,000	>5,000	Committed to reducing emissions by 50% by 2030 and net-zero by 2050. Bringing core technology capabilities to lead in the energy transition and enable a decarbonization path for energy and industry. Accelerating the adoption and deployment of new fuel sources and emission solutions, including hydrogen.
Halliburton	>40,000	>4,000	Develop products and services that enable customers to reduce their environmental impacts throughout the life cycle of their assets. Halliburton Labs, located in Houston is a collaborative environment where entrepreneurs, academics, investors, and industrial labs join to advance cleaner, affordable energy.

Sources: (Greater Houston Partnership, 2021), (Schlumberger, 2022), (Baker Hughes, 2022), (Halliburton, 2022)

Service companies have a well-established international presence and several of those interviewed described deployed strategies related to electrolyzer plants and decarbonized services and facilities supported by electrolyzer plants. This represents a novel extension of the supply chain which can leverage Houston manufactured electrolyzers to international markets. Closely related to oil services is a large local machinery and fabricated metal industry specializing in oil products. (University of Houston Energy Fellows, 2018).

These companies expressed needs for the most cost-competitive sources of hydrogen to support deployments. They have stated the market costs of hydrogen from commercial suppliers coupled with the cost of transporting to remote locations are “showstoppers”. In response, they are piloting applications for field generation and storage of hydrogen in collaboration with electrolyzer/fuel cell technology developers within their Houston facilities. As these applications would be piloted in West Texas, they would be eligible for R&D funding through the Houston hydrogen hub.

Another opportunity for Houston is the service hub for these challenging applications. The projected base of electrolyzers to be built will need to be maintained and serviced. Annual maintenance costs are ~1% of original facility Capex over useful life of 5-15 years.

At the end of life, a stack is typically removing and returned to an overhaul facility for refurbishment or salvage of parts and base materials. Like other generation fleet management practices, this is best performed by the OEM. This will create a secondary revenue stream for services staged from Houston, supplementing manufacturing

revenues. Major European players (such as Nel) derive more than 15% of electrolyzer revenue from services – the proportion which will likely to grow with expansion and aging of the installed base.

#### 4.5. Modular construction

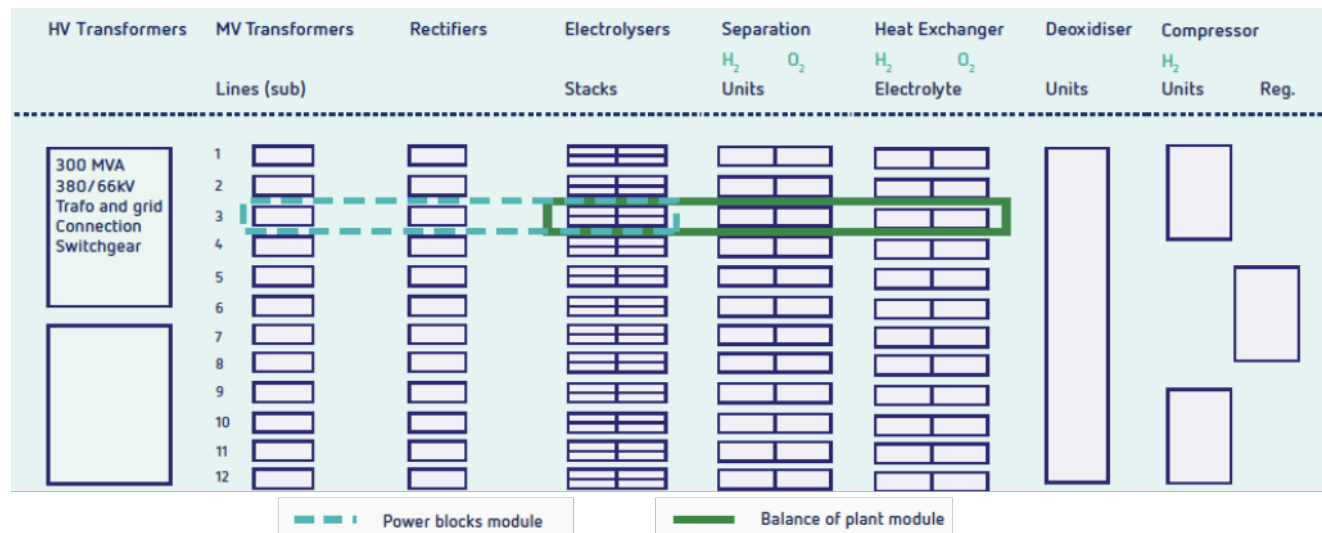
Increasing facility size can result in new challenges negating potential benefits of scale described above. On the other hand, the application of modular concepts can create value by:

- Creating flexibility in terms of phased development, with easy adaptation to newer technology generations.
- Enabling the combination of different electrolyzer plants with potentially different stack generations.
- Enabling standardization and creating competition between components suppliers and module producers.
- Construction of facility modules within factory settings, minimizing costly site construction time and increasing quality.

Modularization creates an opportunity for faster learning and more efficient production, even while scaling up (Flyvberg, 2021). By breaking designs into blocks that can be expanded over time, former portions can keep operating even as new blocks are added to create a larger facility.

Hydrogen electrolyzer facilities are naturally suited to modularization similarly to wind and solar. However, current concepts of modularization for hydrogen electrolyzers are limited in size, typically within a containerized system up to 1 MW. Larger facilities exceed the threshold for containerized designs and the modules break out on a sub-system basis such as stacks, power block and gas purification. Accordingly, modularisation concepts become more complex with larger capacities (Fraunhofer ISE, 2021), as shown in Figure 19.

Figure 19: Modular layout for 12 x 40 mw PEM system



Source: (Fraunhofer ISE, 2021)

Houston-based industry has a long history of modularization within conventional energy systems including multi-well pads, gas plants, offshore platforms and LNG production trains. All these systems share the principle of modules broken out into repetitive units on a sub-system basis. Accordingly, these existing skillsets can be leveraged including:

- Advanced tools such as digital twin designs.
- Virtual walk-throughs to ensure operator ergonomics and serviceability.
- Large module facilities with logistics connections and skilled workforces.
- Experience with precision allowing pre-assembled modules with piping and utility connections pre-planned ensuring hassle-free field connection.



## 5. Expanding electrolyzer market

Summarized below are the overall drivers defining the electrolyzer opportunity, the position of key technologies and Houston's overall merits in relation. These have been synthesized through existing market realities, projections and extensive stakeholder input. This sets the stage for a more detailed discussion of Houston's opportunities in the subsequent sections.

### 5.1. Market history and growth trends

Green hydrogen is expected to move from niche to mainstream by 2030, both globally and within key regions. Estimates for worldwide annual clean hydrogen production in 2030 range from 80 Mt (IEA, 2021) to 154 Mt. The 2030 targets for total installed capacity of green hydrogen electrolyzers are 350 GW (IRENA, 2022). These estimates were based on production and demand prior to the IRA; these new economic incentives will make green and blue hydrogen cheaper than grey long before 2030 and are expected to further accelerate investment and production.

However, production is dependent on cost as well as logistics. Frequently stated bottlenecks to rapid expansion of electrolyzer manufacturing are:

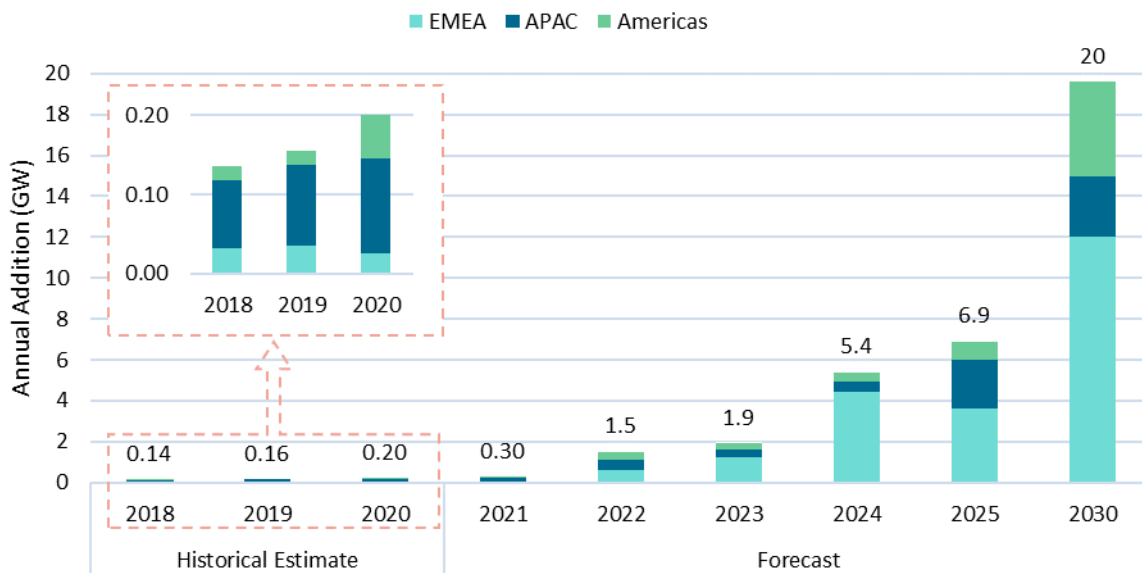
- An incomplete regulatory framework supportive of the large-scale deployment of renewable and low-carbon hydrogen.
- Market uncertainty on the future demand for hydrogen – while supply accelerating rapidly, many of the industries viewed as prime hydrogen markets (steel, trucking, ammonia) are slow to move and not making rapid investments.
- Current scale and lack of integration in supply chains limiting the availability of components and raw materials.

#### 5.1.1. Growth by global region

To match global targets, electrolyzer and component manufacturing capacity must grow dramatically. This includes over 50% average growth per year until 2030, 25% average growth per year after 2030, and stabilizing at 4% per year in 2050 (USDOE, 2022).

As shown in Figure 20, the global market for green hydrogen electrolyzers shows high growth in recent years. Throughout this period most shipments have been destined for the Asia-Pacific (APAC) region.

Figure 20: Historical and forecast annual electrolyzer shipments by region



Source: (BloombergNEF, 2021)

Note: Forecast are based on orders announced by main current manufacturers

Near-term growth projections are frequently revised based on announced additions by manufacturers. Recent projections, as shown in Figure 20, reveal the market is expected to more than quadruple in 2022 and grow over tenfold between 2022 and 2030 (BloombergNEF, 2021). In the nascent growth market, these projections are influenced by policies and direct incentives – many of those projections were created before the IRA was passed. Under these older projections, the largest share of electrolyzers was projected to develop in Europe, but changing incentives have led to a number of companies planning expansion in the US to take advantage of new incentives.

### 5.1.2. US electrolyzer market

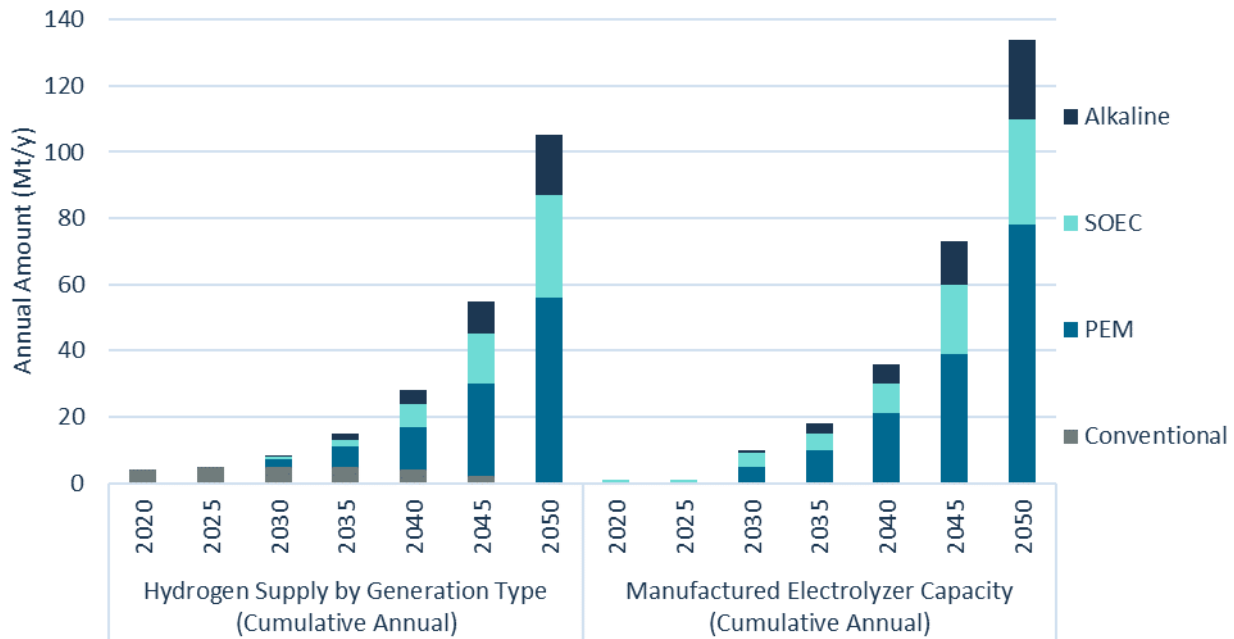
As shown in Figure 21, US generation of green hydrogen is predicted to exceed 100 Mt/y by 2050, approximately 20% of the global market. This includes important implied assumptions (USDOE, 2022):

- No export or import of electrolyzers from/to the USA
- Conservative assumption for electrolyzer lifetime (40,000 h for PEM / 35,000 h for SOEC / 80,000 h for alkaline)

Additionally, the following patterns are predicted in the market growth:

- Conventional hydrogen generation will peak by 2030 and decline to zero by 2050
- The projected annual manufactured electrolyzer capacity is 130 GW by 2050
- Until 2025 nearly all hydrogen is produced from conventional sources
- There will be minimal additional electrolyzer capacity additions until after 2025, growing at a 15% CAGR from 2026 to 2050
- PEM will be the main technology providing supply and new capacity by 2035 and onwards

Figure 21: Hydrogen supply and manufacturing growth projection to 2050



Source: (USDOE, 2022)

### 5.1.3. Growth by electrolyzer technology

The supply chain requirements will vary based on which electrolyzer technology dominates future growth. The overall market for all technologies is only emerging and global manufacturing capacity is limited along with the corresponding supply chains. Recently, alkaline electrolyzers accounted for 85% of electrolyzer manufacturing with PEM electrolyzers accounting for less than 15%.

The predictions for market share of competing electrolyzer technologies vary when the simultaneous market growth for all technologies is considered. Some sources assume 90% of electrolyzer additions required this decade will be alkaline (IRENA, 2022), others give majority to PEM (USDOE, 2022).

The question of technology use comes down to technology maturity, energy characteristics and site parameters. There is no single technology answer in the hydrogen space as different technologies will work best in different situations.

Key organizations and developers are similarly ambiguous on which technology is superior:

- **“Each technology has its own challenges, from critical materials to performance, durability and maturity; there is no clear winner across all applications, which leaves the door open for competition and innovation driving costs down.”** (IRENA, 2020)
- **“Asked...if he sees a ‘winner’ between alkaline or PEM electrolyzer technology sometime in the future, d’Erasmus responded, “Who knows? I believe that both technologies will play a role in the future..... Scale, input power characteristics, electricity cost, and rate of technology development will all likely be factors in which technology fits a given application in a given timeframe.”** (Cockerill, 2021)
- Vice-President of Research & Development at Nel, Dr Kathy Ayers, previously told H2 View that, **“They both have their advantages for different applications, and neither has reached the end point for improvement.”** (Cockerill, 2021)

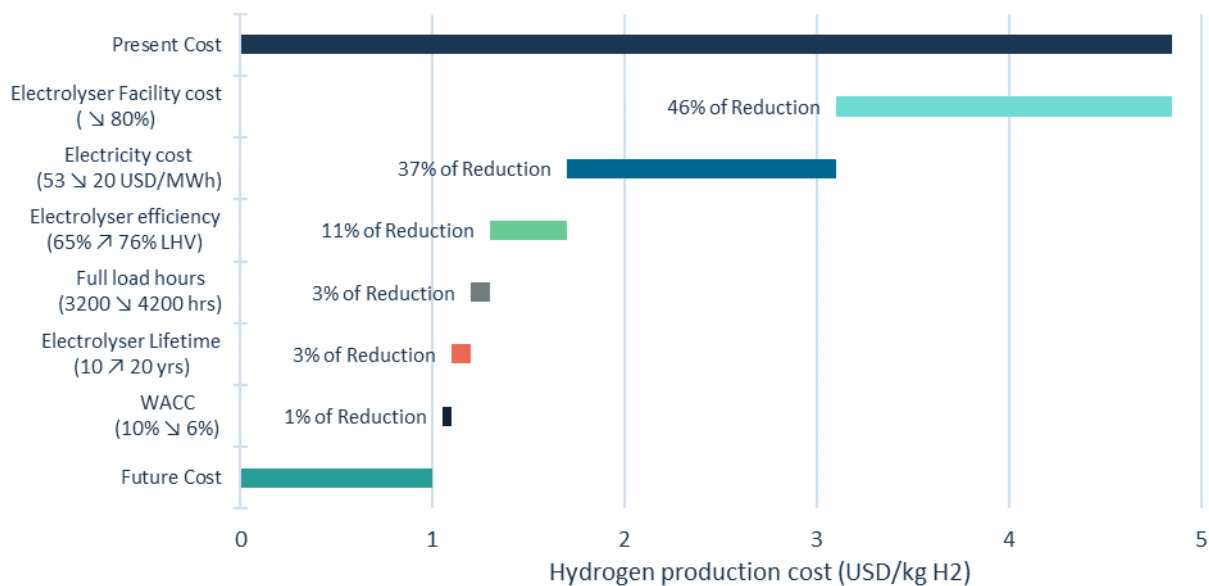
Within stakeholder interviews, manufacturers/producers discussed combining technologies in certain cases. For example, alkaline and PEM may be combined, with alkaline handling electricity baseload and PEM used to handle spikes and drops due to its flexible capacity factor.

## 5.2. Capital cost improvement

Accelerating the deployment of green hydrogen is dependent on large reductions in the levelized cost of hydrogen produced by electrolyzers. A competitive hydrogen hub will need to provide the conditions where these reductions occur, while still offering a profitable market for individual operators. Houston has a history of advancing energy technologies in early stages of development by establishing capital cost improvements.

The commonly stated cost target of \$1/kg H<sub>2</sub> requires realization of several objectives. Figure 22 shows the proportion of hydrogen production cost reduction electrolyzer facilities are expected to deliver through reduced capital costs.

**Figure 22: Measures contributing to hydrogen cost reduction targets**



Source: (IRENA, 2020)

From a manufacturers perspective there are several potential levers for achieving capital cost reductions (Nel, 2021):

- Scale of manufacturing – this is the key lever; most experts believe electrolyzers will exhibit learning curves like solar panels.
- Scale of units manufactured – efficiencies from marginally bigger BOP serving more numerous stacks
- Procurement – purchase scale efficiencies.
- Standardisation – modular and/or standardised design.
- Design improvements - most components are still overdesigned; cost reductions can be found at the cell level, particularly within PTLs, bipolar plates and the costly protective coatings used (IRENA, 2020).

This section provides a high-level breakdown of the capital costs (CAPEX) of procuring and installing a green hydrogen electrolyzer facility from the perspective of the facility owner.

### 5.2.1. Learning rates

Based on experience with maturing technologies, the future potential for cost and efficiency improvement is generally expressed as learning rates (IRENA, 2020) – defined as the fall in unit costs associated with each doubling of capacity. The measurement of capacity serves as a proxy for the level of experience acquired by the supporting industry, which slows down as technologies increase in installed capacity and doubling increments take longer to achieve.

As shown in **Table 5**, these rates differ depending on the component and technology type. For example, BoP has much lower learning rates as these technologies are quite mature. Among electrolyser technologies, the current Alkaline configurations are considered more mature than solid oxide or PEM technologies. Solid oxide learning rates are not included in the table below, as these are highly assumption dependent due to low maturity. This is covered in detail in the SOEC section.

**Table 5: Learning rates for different technologies and components**

Part	Component	Learning rate
Stack	PEM - Membrane and BPP	18%
	Alkaline - BPP, membrane, electrodes	15%
	PEM - Other stack type	15%
	Alkaline – Other stack type	5%
BoP	Power supply	12%
	Utilities	7%
	Other BoP	10%

The overall learning rates for a technology like hydrogen are boosted or constrained by the learning rates for the underlying technologies and components including (IRENA, 2021):

- High learning rates ≈18% for components undergoing improvement such as bipolar plates and membranes
- Medium learning rates of 10-12% for manufacturing processes and components being adapted to electrolysers such as machining and power supplies
- Lower learning rates of 5-8% for components and processes that are mature and imported from other industries such as seals, small parts and gas conditioning

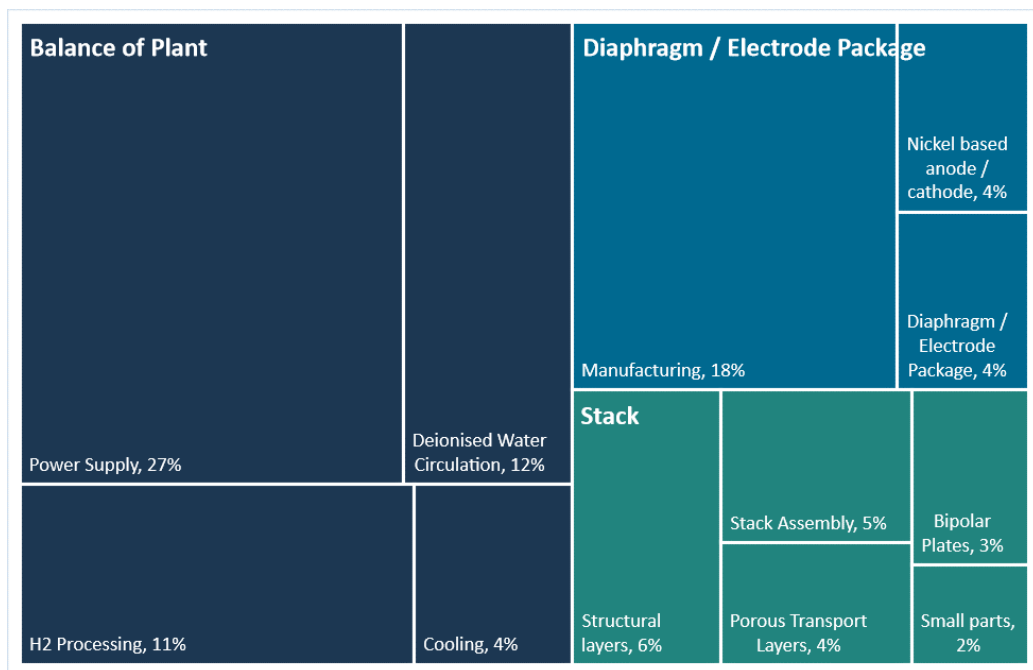
The ability to achieve these learning rates is constrained when manufacturers are located far from suppliers and other manufacturers.

### 5.2.2. Alkaline

#### Base costs

A detailed capital cost breakdown for an alkaline electrolyzer is provided in Figure 23, including BoP. The stack costs represent a quarter of the facility cost, with over half of electrolyzer stack costs related to manufacturing and assembly rather than components themselves.

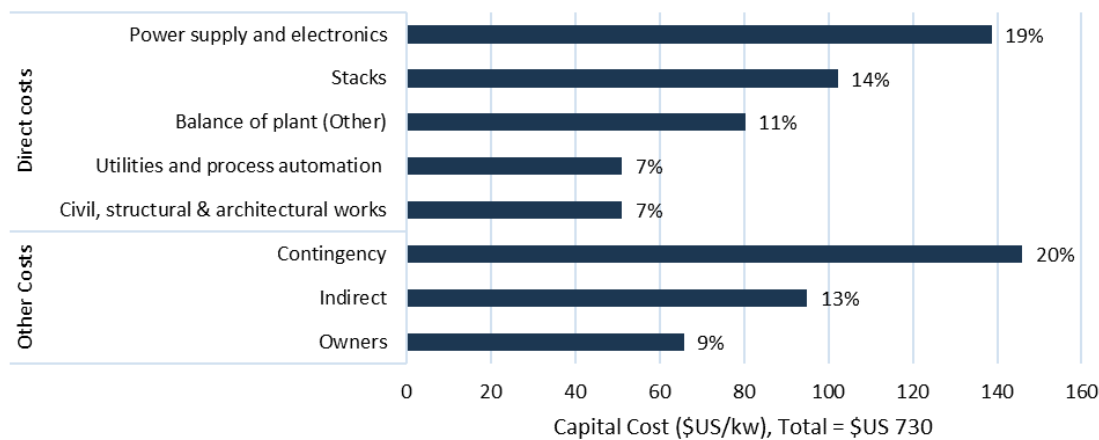
**Figure 23: Alkaline Facility Cost breakdown (1 MW basis in 2030)**



Source: (IRENA, 2020)

Total estimated development costs for a larger scale facility are shown in Figure 24. This highlights the significant cost contribution of other cost factors.

**Figure 24: Alkaline electrolyzer facility direct capex (1 GW basis)**

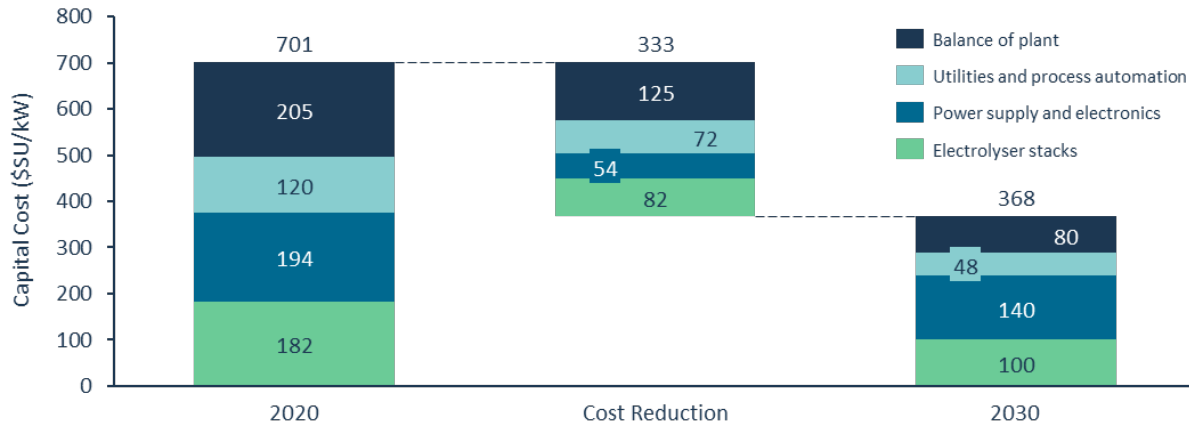


Source: (ISPT, 2022)

**Cost improvement**

The cost of alkaline electrolyzers is expected to decline by 40-50% over the coming decade, as shown in Figure 25. The cost reduction is primarily due to increased economies of scale within BoP components.

**Figure 25: Projected cost reduction for alkaline electrolyzer (1 MW Basis)**



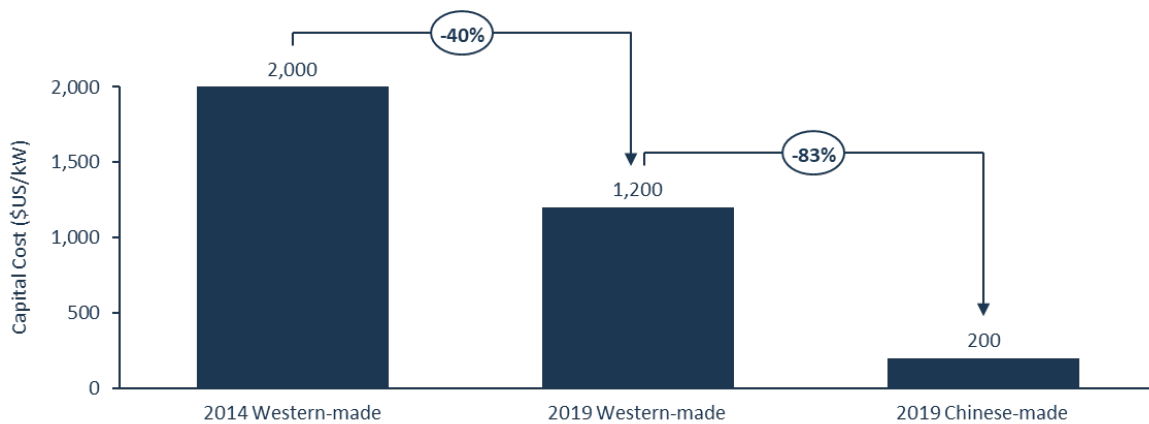
Source: (ISPT, 2022)

Expected technology related cost improvements are due to (IRENA, 2020):

- Increasing current densities
- Increasing the limit for the operating temperature
- Reducing diaphragm thickness to improve efficiency and reduce electricity consumption
- Re-designing catalyst compositions
- Moving electrode architectures into high specific surface area
- Introducing novel PTL/electrode concepts

Alkaline electrolyzers, a more mature technology, have already experienced material reduction in costs. This maturity also makes alkaline electrolyzers more accessible to low-cost country producers. Figure 26 shows the cost reduction occurring over 5 years in western countries as well as the large additional cost reduction achieved in Chinese produced electrolyzers due to cheaper raw materials, higher factory utilization and lower R&D spend.

**Figure 26 Benchmark system capex based on large-scale alkaline electrolyzers, 2014 and 2019**



Source: (BloombergNEF, 2020)

However, electrolyzers produced and installed in China are believed to be less efficient and reliable than those in western countries. Despite being over 80% cheaper in capital costs, this could result in a higher levelized cost of hydrogen (CHEFCIISA, 2021) associated with:

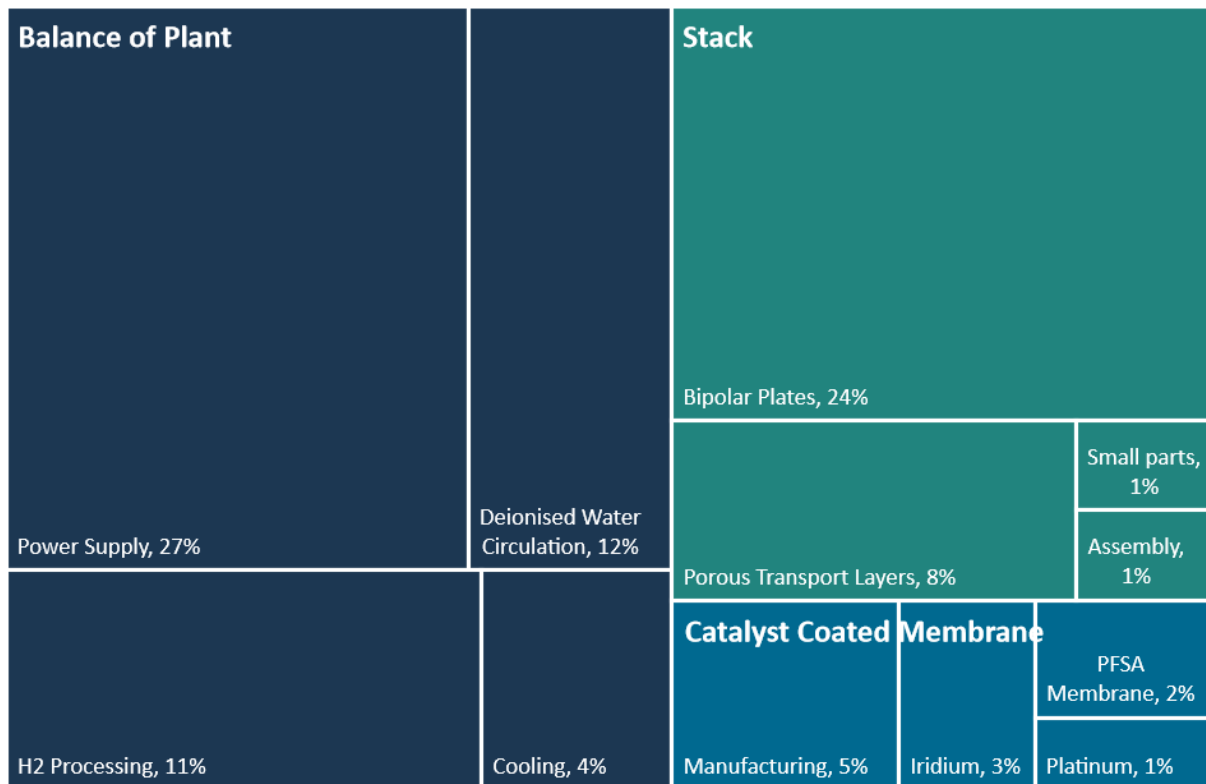
- Reduced efficiency from less advanced heat reclamation technologies
- Less efficient management of gas flow
- Less effective control systems resulting in less balanced loads
- Higher rates of degradation resulting in reduced lifetimes
- Thicker separators in the electrolyzer stacks (1mm compared to less than 0.5mm in the West) resulting in lower current densities and therefore lower efficiencies
- Inferior core materials as electrodes tend to be made from porous nickel – most alkaline electrolyzers in Europe use high-performance nickel-based alloys

### 5.2.3. PEM

#### Base Costs

A typical capex breakdown for a PEM electrolyzer is shown in Figure 27, including BoP. This reflects a typical current, small-scale facility.

Figure 27: PEM Facility Cost breakdown (1 MW basis in 2030)

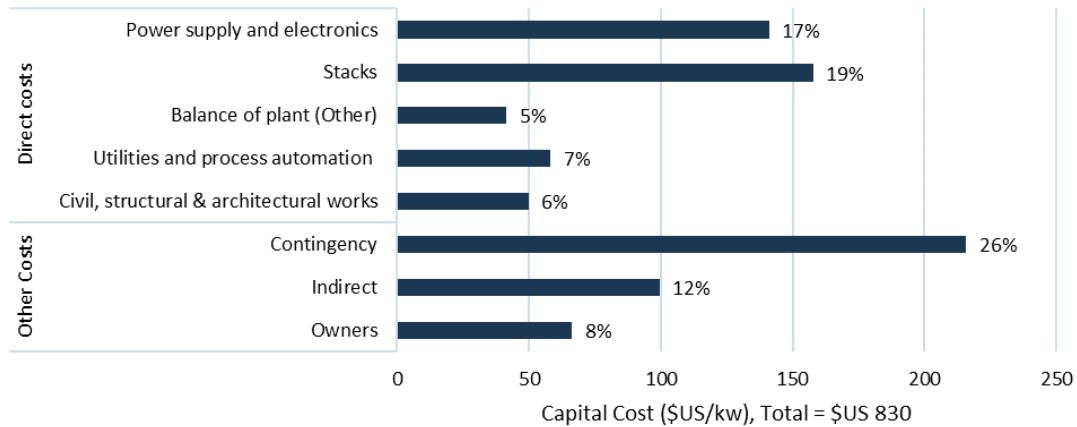


Source: (IRENA, 2020)

Total estimated development costs for a larger scale facility are shown in Figure 28. This highlights the significant cost contribution of other cost factors.



Figure 28: PEM Electrolyzer Facility Direct CAPEX (1 GW basis)



Source: (ISPT, 2022)

PEM cost structure, while similar to alkaline, features high share of stack costs due to the usage of platinum group metals and titanium. These materials represent a significant share of overall costs. Given a variety of technological options for the PEM stack, the cost structure may vary, particularly in relation to platinum group metal use.

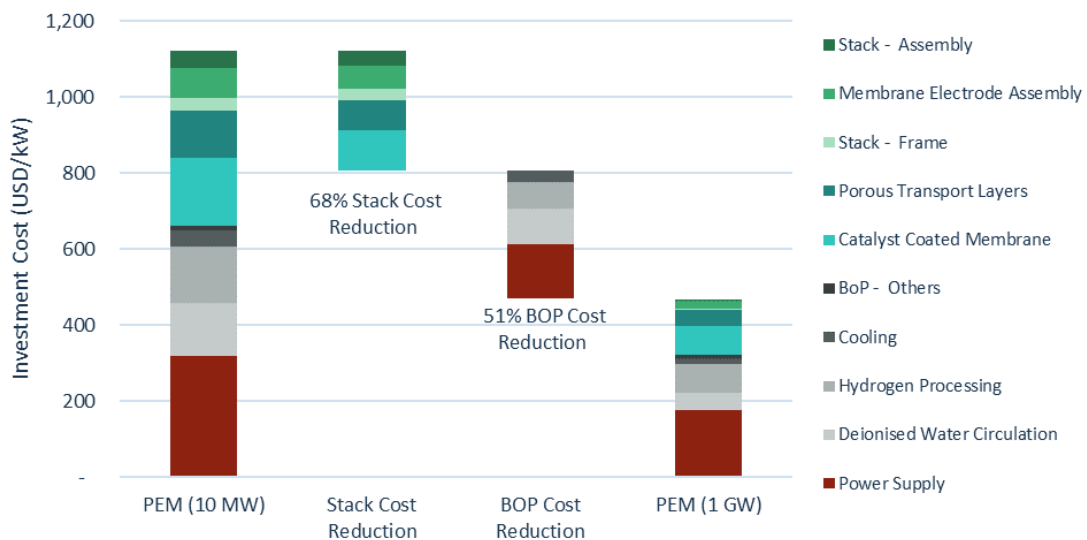
**Cost Improvement**

Cost improvement is mainly associated with stack cost reductions including improved cell design with high-performance materials, innovative electrodes and a larger cell surface area.

Figure 29 shows the potential effect of a hundredfold increase in the size of a PEM electrolyzer facility including:

- Cost reduction both proportionally and overall is within the electrolyzer stack.
  - Frame components and assembly costs have the greatest proportional reductions through greater material and labour efficiency.
  - Membranes and porous transport layers have substantial but proportionally smaller cost reductions as flux rate limits material efficiency.
- Balance of plant cost reduction is also substantial, but the cost reduction is predicted to be more limited.

Figure 29: Projected PEM electrolyzer facility cost reduction through increased scale in 2020



Source: (IRENA, 2020)

Cost reduction beyond scale efficiencies require design enhancement through:

- Reducing diaphragm thickness (to improve efficiency and reduce electricity consumption).
- Reducing catalyst quantities after reengineering electrode concepts.
- Removing or substituting expensive coatings (platinum group metals) on PTLs.
- Developing novel concepts for recombination catalysts.
- Reduced power electronics cost.

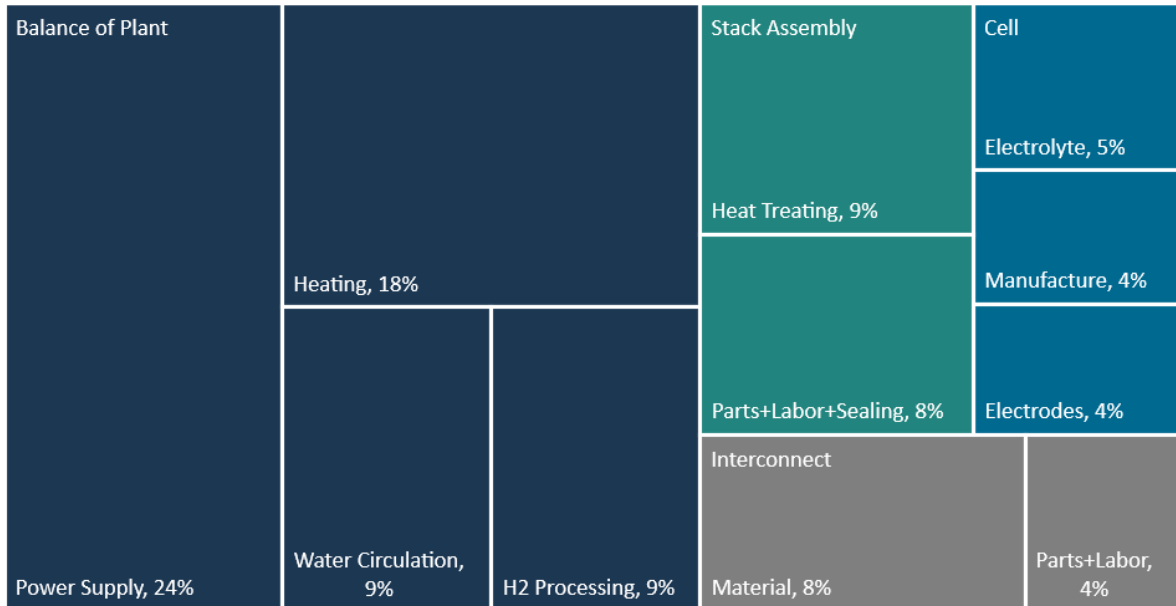
(IRENA, 2020)

### 5.2.4. SOEC

#### Base Costs

There are few available data points for SOEC due to its less mature status. The estimated costs for a facility are shown in Figure 30.

Figure 30: SOEC facility cost breakdown (1 MW basis in 2030)



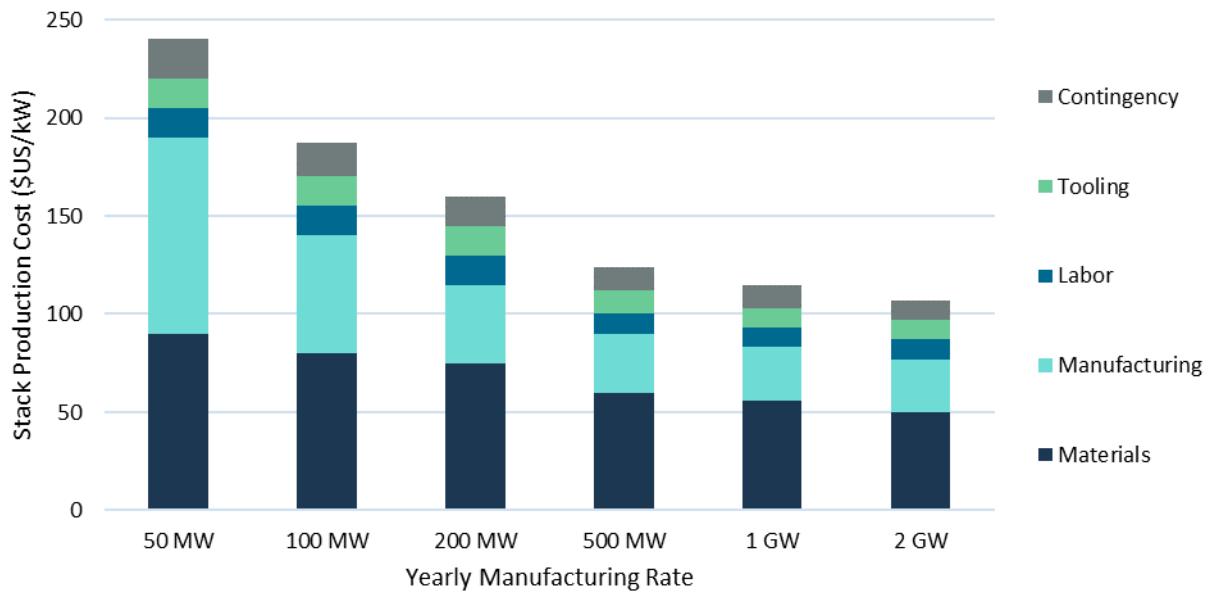
Source: (IRENA, 2020) and (James, Prosser, & Das, 2022)

As with other technologies, the overall cost is driven by BoP components, although these are still not well understood at scale and are dependent on how the supplementary heat is supplied.

#### Cost improvement

Like PEM, solid oxide electrolyzer costs are also expected to exhibit economies of scale with manufacturing being key to cost reduction with scale. However, with SOEC at a currently low-capacity base, these values are highly speculative. The predicted cost reductions for SOEC stacks with increasing production are shown in Figure 31.

Figure 31: SOEC stack cost reduction with increasing manufacturing scale

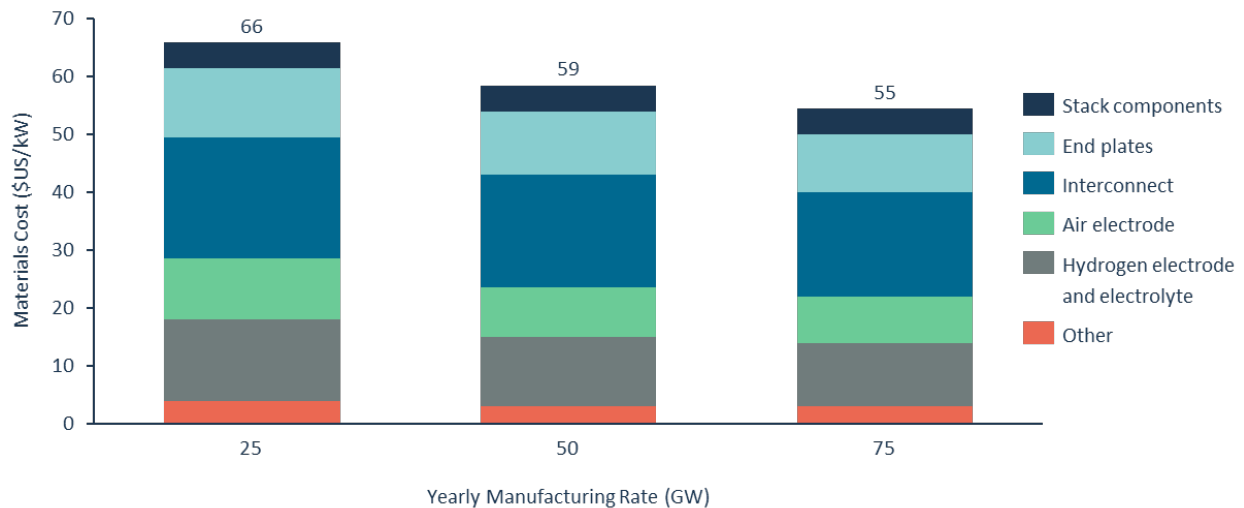


Source: (USDOE, 2021), (James, Prosser, & Das, 2022)

As shown in

Figure 32, there are also limited opportunities with the cost of materials, predominantly cell components (nickel oxide powder), air electrode powder, interconnects, and end plate metals.

Figure 32: SOE cost of materials by component with increasing manufacturing scale



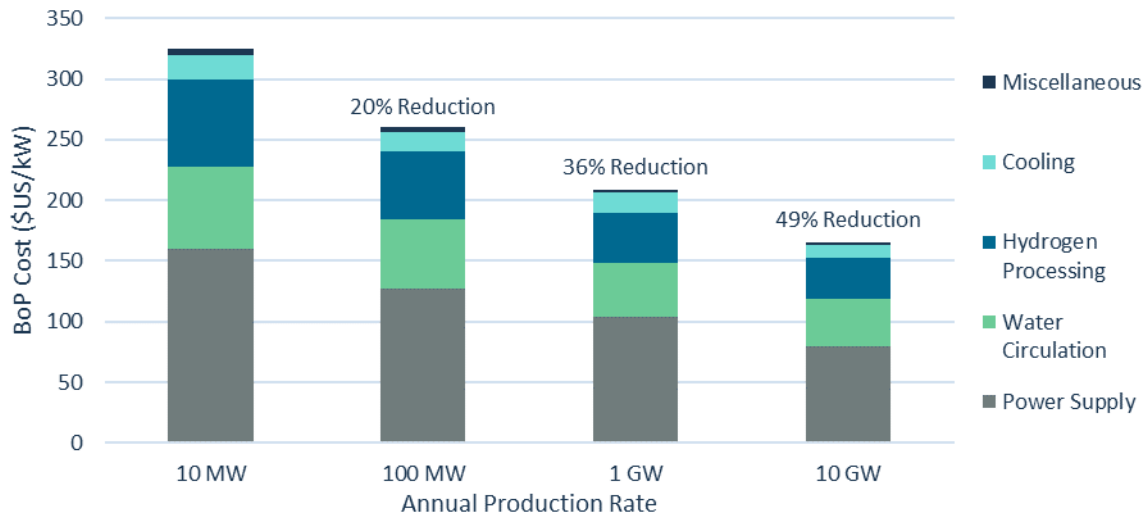
Source: (USDOE, 2021)

### 5.2.5. Balance of plant

As the largest contributor to overall facility costs, BoP also provides the greatest opportunity for system cost reduction across all electrolyser types. BoP components are mostly outsourced to specialized manufacturers but as hydrogen electrolyzer demand increases they will provide procurement related economies of scale (NREL, 2019). Most balance of plant technologies are mature, so cost reductions are related to economies of scale, standardization of design and supply chains, and modularization (IRENA, 2020). As economies of scale are reached,

standardization of design and supply chains drives further reductions (note that all the produced facilities have a similar scale). The greatest overall cost reduction impact is in the Power Supply category – currently very expensive and expected to decrease as supply chains scale and designs standardize.

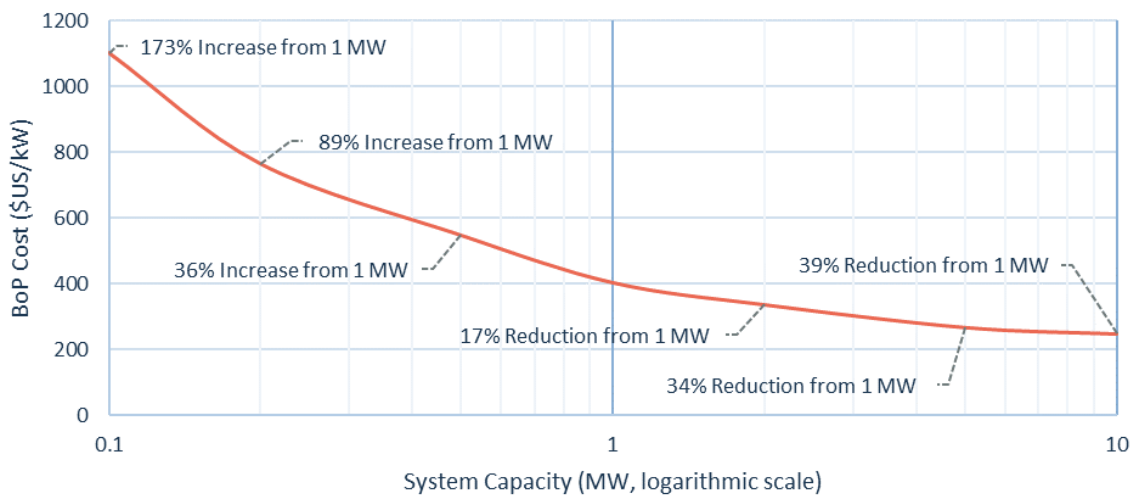
**Figure 33: Breakdown of BoP costs for 1 MW plant as a function of the annual production rate**



Source: (NREL, 2019)

Another demand-driven opportunity is system size increases which improves efficiency. As shown in Figure 34, the effect of system size is dramatic at small capacities, but much smaller improvements are possible as system capacities ~ 10MW are reached.

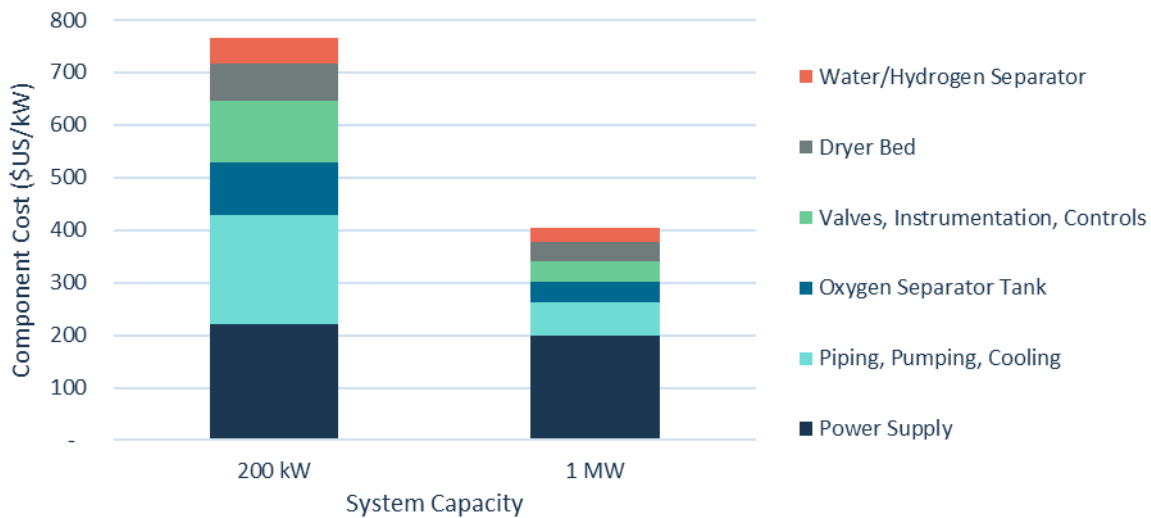
**Figure 34: BoP cost effect of PEM system capacities**



Source: (NREL, 2019)

The underlying effect of scaling on individual components can be seen in Figure 35. This only includes the component cost for a single system. There are strong cost efficiencies gained across most components (>50%), while the cost efficiency on power supply components appears much lower (~10%). Referring to Figure 35, this explains power supply cost become dominant at larger system capacities.

Figure 35: Cost of components compared for different system capacities



Source: (NREL, 2019)

### Power supply

Half of the cost for BoP is related to power supply. Considering the dynamic of the power inverter market (5% per year growth in the future) and a future demand for tailored electrolysis solutions, further cost reductions of about 25% by 2030 can be expected as the market scales (Fraunhofer ISE, 2021).

Utilizing classic, low-voltage inverters from wind and solar industries could present a cost advantage in the future, but the minimum DC voltage is limited to the input AC- peak voltage. This makes additional DC-DC converters necessary, increasing cost and complexity.

Another approach is to lift the DC voltage of the rectifier to the upper limit of the low voltage directive (up to 1.5 kV) by connecting stacks in series, enabling the use of suitable components with a higher-rated power and bringing the cost down. However, research on potential risks for the operation of the stacks (e.g., series resistances and leakage currents) still needs to be completed.

### Water circulation

Water circulation equipment capex is related to the cost of the oxygen separator tank. If produced oxygen is not captured, this can lower costs by 65-75% -- economics for the utility of oxygen need to be conducted.

Instrumentation includes pressure, temperature, conductivity and flowmeter. Increased cost for these components is driven by Class I certification requirements for locations with flammable vapours and gases.

### Gas purification

Sizing-up the components of the gas purification unit (such as deoxidizer, heat exchangers and columns for temperature swing adsorption), respective to the system capacity, offers a huge cost advantage (Fraunhofer ISE, 2021). One reason for this can be similar cost expenditures for designing and acceptance testing of the pressurized gas purification components, independent of their dimensions. These components are also easy to scale in size, meaning many stack arrays can be connected to one gas purification unit to reduce per kW costs.

### Compression

The compression unit offers cost reductions by sizing-up to larger capacities. Compressors for process gases are widely used in industry (Fraunhofer ISE, 2021), but many manufacturers are developing or adapting their conventional (reciprocal and centrifugal) compressors for hydrogen usage. Thereby, reciprocal compressors are the most mature and efficient solution in the targeted capacity class. It can be assumed the cost reductions

through improved performance and reliability of MW-class hydrogen compressors will increase in the coming years as more systems are built.

Other promising compression technologies, such as external electrochemical compressors, are on the verge of entering the hydrogen refuelling station market with several small-scale pilot plants in operation. They can combine hydrogen purification and compression in one unit, allowing for increased efficiencies and cost reductions.

### 5.3. Critical materials supply chains

High performance materials are a key input in achieving the innovations to increase hydrogen electrolyzer performance. This is a critical area of R&D and competitive advantage for the private sector, as confirmed by stakeholder interviews. Electrolyzer stack materials are a challenging portion of the supply chain and a potential obstacle in establishing a full electrolyzer value chain as they:

- Are the least produced portion of the value chain in Houston.
- Tend to be located where the company originated, often adjacent other industries the producer originally served, original R&D facilities, or other non-value driven reasons.
- Stakeholders indicated as being the least likely to migrate, even with a growing local market.
- Are dependent on critical raw materials at risk of scarcity, cost escalation and legislated restrictions.

The United States is a global supplier for portions of the raw and processed materials contributing to the electrolyzer value chain including:

- 60% of ionomers like Nafion™ (for electrolyte membrane)
- 20% of carbon cloth/paper (for GDLs)
- 27% of stainless steel and 30% of carbon fibre (for bipolar plates and pressure vessels)

However, gaps in supply will affect the potential rate of deployment for the overall industry, including Houston. This section describes several key materials and equipment identified as challenges to cost, ability to scale and overall supply chain stability.

#### 5.3.1. General metals demand

In general terms, all electrolyzer designs are metal intensive. Copper, aluminium, and steel demand can be met through existing supply chains, but additional demand will likely press beyond current capabilities – particularly when combined with demand from other energy transition industries such as energy storage or renewable generation. For example, current Alkaline designs are noted for not requiring expensive catalysts but still require the following metals per MW capacity (IEA, 2022):

- One tonne of nickel
- 100 kg of zirconium
- 0.5 tonne of aluminium
- 10 tonnes of steel
- Smaller amounts of cobalt and copper catalysts

There are concerns the global roll-out of electrolyzer manufacturing capacity will be constrained by availability of critical materials. To meet expected demand, large increases in extraction and refining materials will be required. Many of these are fulfilled by imports with no specific plans for domestic production (USDOE, 2022). This includes:

- Nickel and titanium
- Iridium, yttrium, platinum and strontium for catalysts
- Graphite and carbon fiber for bipolar plates and pressure vessels

In response to the anticipated scarcity, these materials are on critical materials lists in the European Union, Canada and the United States. These lists vary in number and ranking of included mineral commodities, but generally include the same ones. Rare-earth elements and platinum-group elements are generally accepted as critical (USGS, 2017).

The future free economic flow of these metals will likely be impaired or intervened in by regulations as they are critical to national security and economies. For example, in June 2022 President Biden invoked the Defence Production Act (DPA), granting emergency funding to the USDOE for expanding clean-energy sectors. The support can also be applied through the supply chain for raw material exploration, mining, synthesis and purchasing (Parkes, 2022).

The USDOE recommends establishing domestic capacity for processing raw materials, catalysts and cell materials containing platinum and iridium to support building out PEM capacity. Specific actions have been considered to address these challenges including (USDOE, 2022b):

- Provide support to PGM catalyst industries to enable decarbonization.
- Develop substitutes to reduce reliance on iridium-based anode catalysts in PEM water electrolyzers.
- Develop and commercialize technologies for recovering PGM from end-of-life PEM fuel cells and water electrolyzers.
- Expand PGM mining and refining in the United States.

In the future, the recycle streams associated with end-of-life PEM fuel cells and electrolyzers will need to be recycled to recover these high value materials, including:

- Platinum (electrolyzer cathode, fuel cell cathode and anode) and iridium (electrolyzer anode)
- Titanium (bipolar plate and anode)
- Graphite (bipolar plate)
- Aluminum (base plate), copper and nickel (anode catalyst, bipolar plates)

### **5.3.2. Platinum group metals importance**

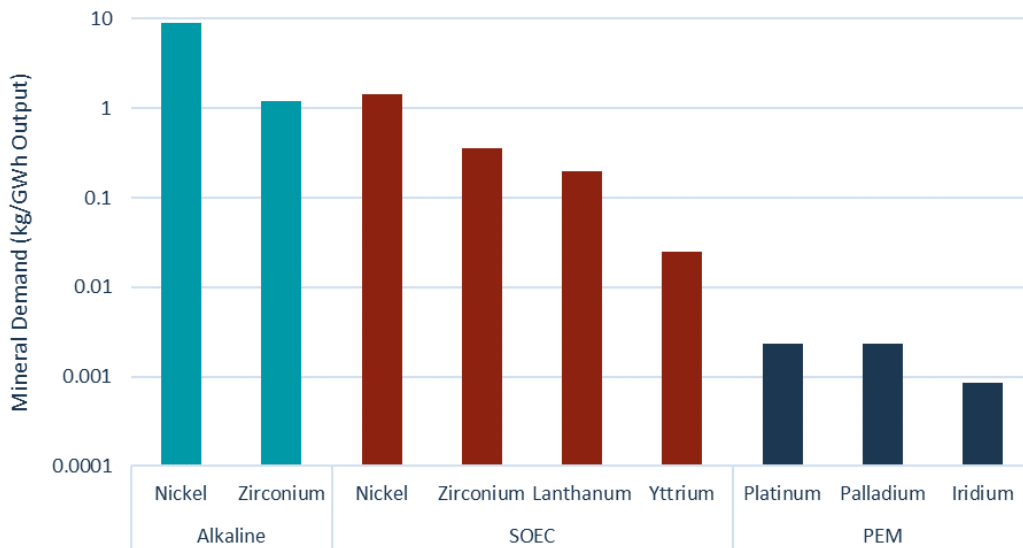
Platinum group metals like iridium are seen as potential bottlenecks for ramping up the electrolyzer supply chain (USDOE, 2022) given they are:

- Globally scarce, by-product materials from production of other base metals and refineries.
- Subject to ESG concerns in the developing countries where many mines are placed.
- Import dependent as they are not produced or refined within the United States.
- Have high and fluctuating costs.
- Poorly recovered at end-of-life with low rates of overall recycling.

#### **Demand**

The relative amounts of critical metals within different electrolyzer types are shown in Figure 36. Nickel use in alkaline is the largest metal use shown while Iridium use in PEM is approximately 10,000x less on an equivalent output basis. These two metals represent a similar per unit cost per unit output due to iridium's extreme scarcity and price.

Figure 36: Estimated leveled demand for selected minerals in electrolyzers

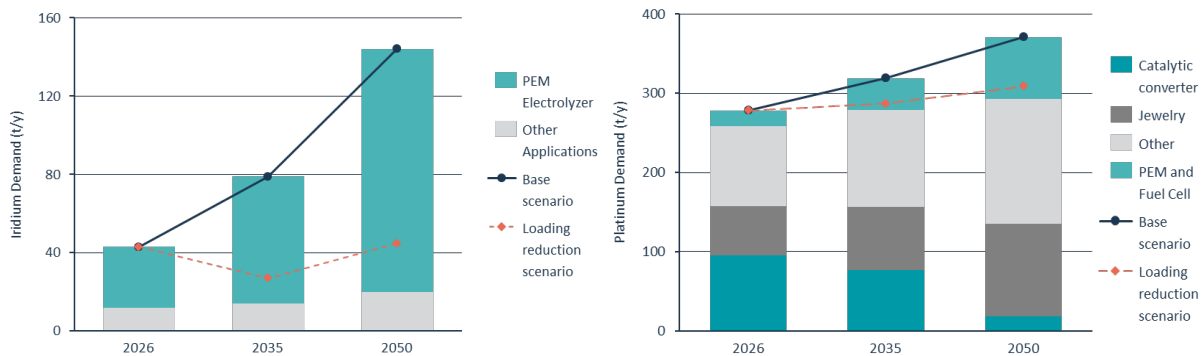


Source: (IEA, 2022)

As shown in Figure 37, significant additional demand for key PGM is possible under future expansion scenarios:

- PEM is expected to account for 70% of iridium demand by 2026 with further scale up requiring a hardly realizable over 300% supply increase. Aggressive technology improvements with an 80% membrane loading reduction by 2035 (from 2 to 0.4 mg/cm<sup>2</sup>) are required to maintain current supply rates.
- PEM and fuel cells are small portion of platinum demand so far, however scale-up may increase to 20%, with global demand increasing 33%. Aggressive technology improvements with an 80% loading reduction by 2035 would mitigate this impact.

Figure 37: Global iridium and platinum demand projections



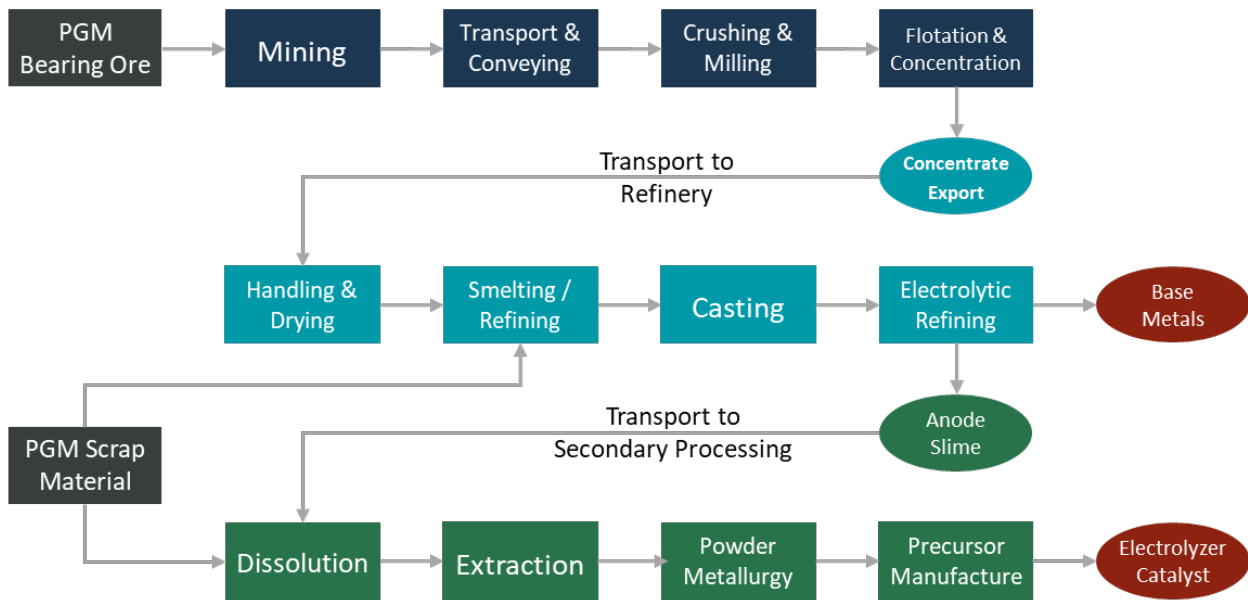
Source: (USDOE, 2022b)

### Production

These critical materials occur at the beginning of the value chain for electrolyzers, and they may pass through several processes before being used in a final electrolyzer product. The production of many of these metals is complex as they are not produced directly but are co-produced in small quantities from other metal bearing ores, smelting/refining and secondary (scrap) sources, as shown in the figure below.

Figure 38: Production of PGM catalyst through current routes

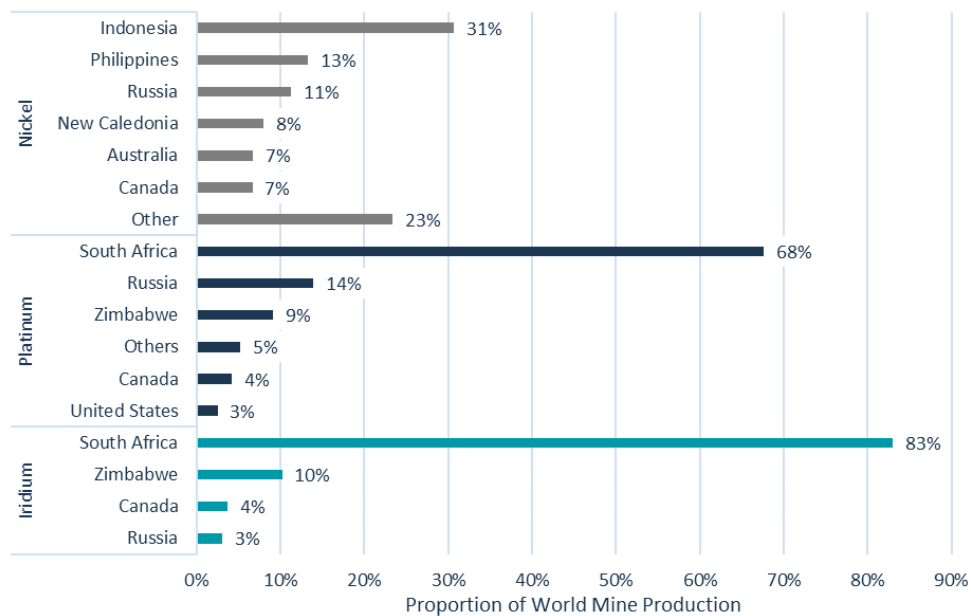




Source: (USDOE, 2022b)

The overall global mining production of these metals varies, with nickel production being distributed and the US producing <1%, whereas platinum and iridium production is highly concentrated in South Africa, as shown in Figure 39.

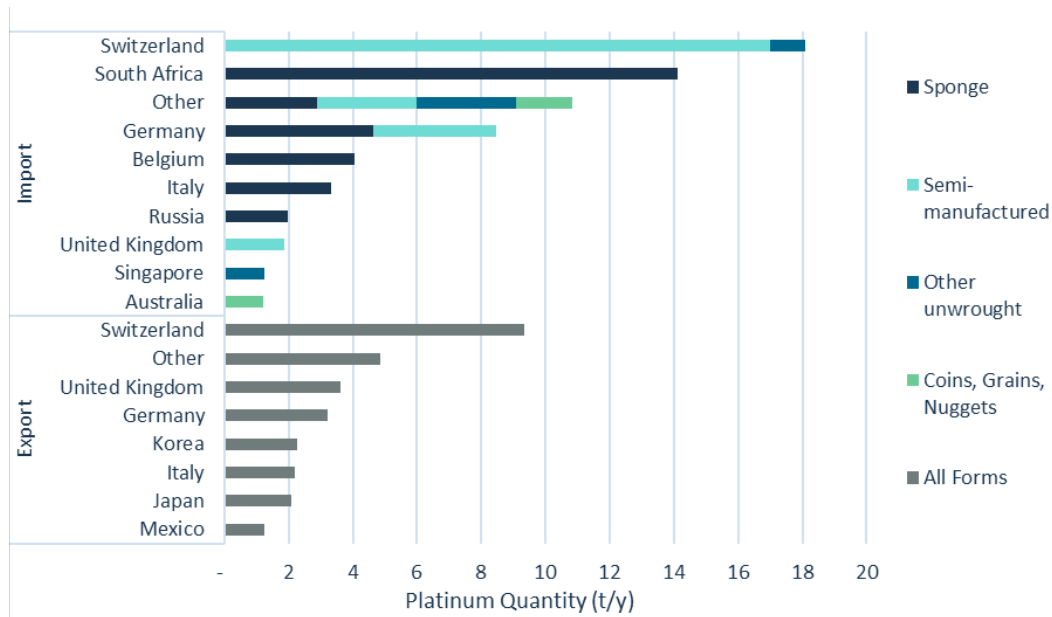
Figure 39: World mine production of nickel, platinum, iridium in 2020



Source: (USGS, 2022), (USDOE, 2022b)

The balance and forms of trade using platinum as an example is shown in Figure 40. Although the US imports PGM metals such as platinum, about 50% is re-exported in various forms. In addition, while South Africa is the main source of mined and primary forms of platinum, the greatest trade flows are with Switzerland, which is a major trading, refining and vaulting center for precious metals (Reuters).

Figure 40: Platinum imports and exports from the US in 2020



Source: (USDOE, 2022b)

The capital cost of the electrolyzers and PEM is sensitive to fluctuations in metal prices which have been volatile over the past 5 years, as shown in Figure 41.

Figure 41: Platinum and iridium price over the past 30 years



Source: (Matthey, 2022)

**Recycling**

The developing market has a lack of local recycling facilities for end-of-life materials associated with electrolyzers. Recycling and secondary streams provide 20% - 40% of total global PGM supplies (USDOE, 2022b). There is also an initial higher proportional volume waste material in developing technologies due to:

- Higher rate to rejection due to off-spec production or failed factory acceptance testing.
- Shorter initial lifespans as technology improvements are being learned (run to fail).
- Obsolescence of earlier generations of technology as it becomes more economic to replace with higher efficiency and capacity versions.

These trends have been observed in other energy transition technologies such as solar and batteries. This increases the volume of critical materials required and attracts negative stakeholder perception. Applying circular economy principles can assist in these challenges. The industry should ensure there is sufficient competence and capacity to recycle components for electrolyzers and fuel cells. This is particularly challenging for PGM loaded cell components.

While recovery technologies are mature, their specific application to electrolyzers and fuel cells requires further research. This is an opportunity for Houston to gain a technological edge by leveraging its R&D capabilities. Houston is already a key collection point for complex end-of-life materials such as catalysts used in refining and chemicals.

### 5.3.3. Advanced carbon materials

Graphite and carbon fiber have potential to produce future performance improvements in applications like catalysts, hydrogen storage tanks and other lightweight structural elements. About 90% of the carbon fibers produced are made from polyacrylonitrile. The remaining 10% are made from rayon or petroleum pitch. These feedstocks are mixed with other materials and then spun into fibers by various methods. They are then washed, stretched and stabilized into a directional fiber.

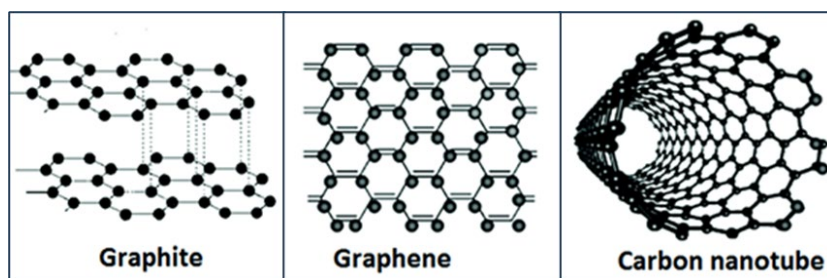
Composite fibres important to advanced hydrogen storage vessels, comprising up to 60% of cost. Only a few global suppliers exist (Toray, Hexel, Mitsubishi, Solvay, etc.) with several manufacturing facilities in the United States. Carbon fiber consumers interviews revealed a lack of capacity and supply is becoming a challenge, with prices almost doubling in 2019, then scaling back in 2021. New carbon fiber plants are expensive and complicated by the varieties of product specification. Given there are multiple applications for composite fibers (aerospace, defence, 3D printing) with others on the rise, the situation is unlikely to improve in the short-term.

Graphite is a naturally occurring form of pure carbon useful within batteries, fuel cells and electrolyzers. It is primarily produced in Asia, and two-thirds of graphite is produced synthetically using high temperature heat treatment. It is generally of a higher purity, but 4-7x more expensive than natural graphite. The remaining portion of market graphite is mined with 68% of production concentrated in China. The United States has not domestically produced natural graphite since the 1950s but does produce substantial quantities of synthetic graphite. Graphite prices are subject to negotiation between buyer and seller and are not traded on any commodity exchange (USGS, 2017).

As shown in Figure 42, at the molecular scale, several carbon-based nanostructures can be formed. This includes materials relevant to the electrolyser value chain including:

- Graphene – a single atom layer of the graphite material or carbon atoms joined in a honeycomb lattice.
- Carbon nanotubes – single atom walled lattice of carbon atoms forming a tube of indeterminate length.

**Figure 42: Carbon based nanostructures**



The materials have enhanced properties over graphite like conductivity and strength. They are developed for advanced use in electrodes, gas diffusion layers and catalyst supports. The future availability of high-purity graphite is one of the key material supply challenges for an expanded industry and a key area of potential

advancement (USDOE, 2022). However, this can be overcome by developing and expanding synthetic graphite capacity within the USA.

The production of carbon nanomaterials is an area of high commercial and development interest, with many competing emerging technologies. Several pyrolysis-based hydrogen generation processes under development aim to co-produce solid carbon products including carbon black and advanced carbon nanostructures (IEA, 2021).

#### 5.4. Emerging policies prioritising green hydrogen

Hydrogen has been receiving a great deal of policy attention, with more than 30 countries having developed or preparing hydrogen strategies. The coming years are expected to bring actions across jurisdictions to develop the global market and reduce costs. Key areas of development include (IRENA, 2022):

- Guarantees of origin
- Support schemes to cover the cost gap for green solutions
- Terms for international trade of hydrogen
- Sharing market intelligence
- Research and Development

These policies are generally being led by the European Union, where manufacturers are collaborating with the European Commission to make combined commitments to rapidly increase manufacturing capacity. However, the US has jumped ahead with blue and green hydrogen acceleration policies by passing the IRA in 2022. The policies focus on gaps preventing growth including adequate regulatory frameworks and subsidies for large-scale green hydrogen production (Collins, 2022b). Some key policies are described within this section.

##### 5.4.1. Guarantees of origin

The advent of green hydrogen certification is key for establishing a potential market premium. Green Hydrogen Organization (GH2) has released a standard for green hydrogen to shore up its climate credentials, prevent greenwashing and help it stand apart from other H<sub>2</sub> colours. The GH2 definition builds on the methodology proposed by the International Partnership for Hydrogen and Fuel Cells in the Economy (IPHE) which works towards harmonising the carbon intensity definitions of various types of hydrogen. (Parkes, 2022)

Key aspects of the proposed standard include:

- Setting a clear definition of green H<sub>2</sub> as “hydrogen produced through the electrolysis of water with 100% or near 100% renewable energy with close to zero greenhouse gas emissions (less than or equal to 1kg of CO<sub>2</sub>e per kg H<sub>2</sub> taken as an average over a 12-month period).”
- Allowing flexibility on the requirement for 100% renewable power.
  - Non-renewables to be used for back-up systems.
  - Power used for associated processes such as water treatment and desalination.
  - Emissions from these systems must not push the production of the fuel over the average annual 1kg CO<sub>2</sub>e / kgH<sub>2</sub> mark.
- Imposes environmental, social and governance (ESG) obligations on producers.
  - Demonstrate engagement with local communities and stakeholders on projects.
  - Considering the social and environmental impacts of new developments.
  - Consider and comply with international standards of human rights in the development and operation of their projects.

Producers hoping to operate under the standard will be assessed by GH2 accredited Independent Assurance Providers. These providers will report to GH2's Accreditation Body, which will make the final decision on whether standards have been met. Projects meeting the requirement will be permitted to use the label “GH2 Green

Hydrogen” and can obtain and trade GH2 Green Hydrogen Guarantee of Origin certificates, tracked by GH2’s official registry (GH2, 2022).

### 5.4.2. Direct subsidies for production

The IRA introduced a direct Production Tax Credit (PTC) for green and blue hydrogen production. These provisions result in 10 years of PTCs for green hydrogen (at \$3/kg H2 produced) and blue hydrogen (at \$0.60-\$1/kg H2 produced) as outlined in the figure below. This makes green hydrogen more economic than grey hydrogen in many cases, which should accelerate demand. However, facilities must still find a source of demand for their products; the PTC is not enough to pay for the current cost of green hydrogen production.

Figure 43: IRA hydrogen benefits summary

Mechanism	Excerpt from Inflation Reduction Act	Summary
<b>Production Tax Credit</b>	“the kilograms of qualified clean hydrogen produced by the taxpayer during such taxable year at a qualified clean hydrogen production facility during the 10-year period beginning on the date such facility was originally placed in service”	• If a facility starts construction prior to 1/1/2033, it gets 10 years of PTC credits
<b>Duration</b>		
<b>Amount</b>	“the applicable amount shall be an amount equal to the applicable percentage of \$3/kg [inflation adjusted]” 2.5-4kgCO2/kg H2: 20% PTC; 1.5-2.5kgCO2/kg H2: 25%; 0.45-1.5kgCO2/kg H2: 33.4%; <0.45kgCO2/kgH2: 100%	• Reduction of Green H2 costs by \$3/kg, blue by \$0.60-\$1.00/kg • With this, cheaper GH2 (\$4/kg) and blue (\$1.70/kg) is now cheaper than grey H2 (\$1.30/kg) • Potential feasibility for yellow H2 to receive credits
<b>Lifecycle GHG</b>	“full fuel lifecycle, including all stages of fuel and feedstock production and distribution, from feedstock generation or extraction through the distribution and delivery and use of the finished fuel to the ultimate consumer”	• A 3% methane leak (not uncommon) cuts emissions reductions from 80% to 40% (below PTC). Big problem for blue hydrogen getting high reduction rates.
<b>Electricity double count</b>	“Electricity produced by the taxpayer shall be treated as sold by such taxpayer to an unrelated person during the taxable year if such electricity is used...to produce qualified clean hydrogen”	• Large incentives for integrated developers • Self-consumption doesn’t get nuclear/renewable electricity tax credits, but if used to make clean hydrogen it does • Getting money at both sides and lowering H2 costs
<b>Investment tax credits</b>	“taxpayers [may] treat specified clean hydrogen production facilities as energy property under Section 48” “Alternatively, taxpayers may elect to claim the investment tax credit under Section 48(a) of the (IRC) in lieu of the PTC”	• Can select one option the other, not both • Can get 5x the ITC if invest within 60 days of guidelines being published (not published yet)— otherwise must meet stipulations • Also can get 5x if under 1MW of capacity
<b>Direct Pay or Transfer</b>	“claim the value of the clean hydrogen PTC determined under Section 45V (as detailed above) through a tax refund as if it were an overpayment of taxes”	• Rather than having to use the tax credit to avoid paying taxes, can use the PTC for direct pay from government • Can also transfer these credits to a third party
<b>Stacking Credits</b>	“such energy projects are also eligible for the 10% domestic content bonus credit amount and the 10% increase in credit rate for energy communities as set out in Section 48”	• Can still get additional credits for using domestic content (hard with current manufacturing, but easier as time goes on) • Can get up to 20% more in credits

The key provisions related to hydrogen include (US Congress, 2022):

- Provision of a new production tax credit (PTC) for hydrogen production in the US after December 31, 2022.
- Facility eligible for a 10-year term beginning on the date qualified facility is placed in service.
- Qualified facility would need to begin construction prior to January 1, 2033.
- Base credit rate of \$US 0.60 / kg of qualified clean hydrogen, which would be adjusted for inflation and according to the life cycle carbon intensity of the hydrogen:
  - 20% from 2.5 to less than 4 kg CO2e / kg hydrogen
  - 25% from 1.5 to less than 2.5 kg CO2e / kg hydrogen
  - 33.4% from 0.45 to less than 1.5 kg CO2e / kg hydrogen
  - 100% if less than 0.45 kg CO2e / kg hydrogen
- Top rate is 5 times the base credit rate (or \$US 3 / kg of qualified clean hydrogen) when prevailing wage and apprenticeship requirements are fulfilled.
- Credit not allowed at a facility that includes carbon capture equipment for which a credit is allowed to any taxpayer under IRC Section 45Q for the tax year or any prior tax year.
- Lifecycle greenhouse gas emissions includes emissions through point of production (well-to-gate), as determined under the most recent Greenhouse gases, Regulated Emissions, and Energy use in Transportation model (GREET).

### 5.4.3. Subsidies bridging green hydrogen cost

Contracts for Difference (CfD) are a proposed subsidy scheme promoting the establishment of hydrogen value chains. Under the scheme, end users are paid a subsidy to cover the price differential between a reference price for grey hydrogen (including carbon pricing, where applicable) and the “strike price” for green hydrogen with variations in the structure and administration existing.

This subsidy would reverse to a pay-back if the strike price decreases below the reference price, as may be the situation in Europe due to high natural gas prices. This enables green hydrogen market availability for essentially the same price as grey hydrogen. When CfD are focused on specific geographies or industries, and with carbon pricing varying independently (Collins, 2022b), overall market distortions can be avoided. CfD address several barriers to adoption of low carbon hydrogen including (Hydrogen Council, 2021b):

- Creating a stable revenue stream for producers, even in the absence of carbon pricing, increasing the certainty of recouping production costs for long payback investments.
- Incentivizing private investment and reducing cost of capital through reduction in financial risk.
- Avoids subsidizing fossil fuels while encouraging hydrogen supply.
- Bridges the leap in scale between pilot and commercial scale projects.

The European Commission (EC) is implementing CfD subsidies for green hydrogen “to support a full switch of the existing hydrogen production in industrial processes from natural gas to renewables and the transition to hydrogen-based production processes in new industrial sectors such as steel-making”. These plans reference renewable and fossil free hydrogen, excluding blue hydrogen pathways. These plans have accelerated to reduce dependence on imported natural gas (European Commission, 2022).

### 5.4.4. Establishment of cost indexes

Establishing cost benchmarks for products within a market is critical for creating market awareness and improving investor confidence. Establishing benchmarks within the dynamic and complex electrolyzer market is challenging. Existing Houston based indices involving equally dynamic contexts in hydrocarbon production are widely referenced within the energy industry, including Mont Belvieu Propane and West Texas Intermediate (WTI) Houston.

The current electrolyser market lacks long-term certainty to justify large investments. There is a lack of price signals indicating actual hydrogen costs that are common to global commodities. Deliberate actions can address these challenges to create reference indicators and draw attention to the subject market.

#### Establishing capital cost benchmarks

Comparisons of electrolyzer capital costs are typically based on major technology options (Alkaline, PEM, etc.) and regions of manufacture. Capital cost estimates and benchmarks vary widely, even for mature technologies. The comparison of capital costs is limited by several factors:

- Electrolyzer costs are dependent on manufacturing scale, system capacity, price for key materials and the materials chosen for specific components.
- Inconsistent or undefined physical boundaries (ex. stack, balance of plant, full system) making comparisons difficult across reported data.
- Low production volumes and limited scale of electrolyzer facilities installations (in-line with existing market realities) result in a broad range of cost estimations.
- Uncertainties increase when considering breakdown from components.

- The competitive, emergent status of electrolyzer development means companies treat costs (and breakdowns) confidentially. Through stakeholder engagement, there was little willingness to provide costs amongst technology developers.
- Current reported electrolyzer CAPEX estimates tend to be reported by third parties, particularly those with stated interests in promoting technology adoption and large-scale implementation.
- Cost projections begin with estimated current costs (with inherent limitations) and estimate cost reduction due to economies of scale and cost efficiencies gained as the technology matures (technology learning curve).
- Large projects have emerging complexities due to their larger scale. Interventions in projects by regulators and stakeholders typically increase this complexity.

The consistency and utility of reported data should show improvement as market size grows, but may also be deliberately improved through organized efforts:

- Certainty around capital costs occurs in hindsight after a statistically significant number of projects of similar scale are completed along with transparent and methodologically similar disclosures of costs.
- Greater complexity and transparency in benchmarks are available, allowing breakdown of costs to system and component level.
- Cost trending allowing more insight on learning rates.
- Uncertainties are understood and somewhat mitigated by maintaining a comparative perspective and accompanying guidance on methodology and limitations.

#### **Product pricing indices**

Cost indexes can be developed by considering the underlying cost components (electricity and natural gas) with well-developed markets and indexes. Capital and operational costs are added to these prices, accounting for assumptions and regional factors. This can be transitioned into surveying of commissioned operating projects, forming quotes based on purchase and sale price of hydrogen over time (IRENA, 2022).

When enough suppliers and users are present within the system, the expectation is lower pricing due to a competitive market. Transitioning to a traded hub pricing model will assist in increasing transparency and providing cost risk management as trade contracts are standardised and volumes increase. This may begin with over-the-counter trades and move into an exchange model as volumes increase, where complex financial instruments such as futures and hedging become possible (IRENA, 2022).

S&P Global established a hydrogen assessment service in 2019 which includes global and US regions according to production methods. Assessments include a commodity price and a commodity plus production cost. In the US, this includes SMR w/o CCS, Alkaline Electrolysis and PEM Electrolysis. The US Gulf Coast bases its price on an average of regional power prices as well as physical gas prices from Houston and Henry Hubs (S&P Global, 2022). Other regionally focused price indexes have recently been established. In Germany, E-bridge consulting publishes a cost index for various types of hydrogen excluding capital costs (E-Bridge, 2022):

- Grey hydrogen – Average price for hydrogen produced by steam reformer and emission certificate procured from the EU Emissions Trading System.
- Green hydrogen – Average price of electrolyzer production including green electricity certificate cost.
- Blue hydrogen – Average price for hydrogen produced by steam reforming, including cost of CO<sub>2</sub> capture and emissions certificates for remaining emissions.

#### **5.4.5. Research and Development (R&D)**

R&D is a critical activity for the current stage of electrolyzer market development; major players reported spending 10-20% of revenue on R&D during interviews. Almost all stakeholders interviewed reported R&D access as a major

potential draw in their attraction to a hub center. The exact nature of this draw varied between players – smaller players often reported an interest in creating larger research consortiums to share data and reduce costs, while larger players often sought out more one-on-one contractual relationships with universities or labs in order to better protect their existing or potential future IP. Regardless, R&D is not limited to corporate activities. Best practices prove successful knowledge development requires collaboration between business, government, and academia.

Hydrogen electrolyzers are the target of extensive government support through the consortiums of USDOE, National Laboratories, and the private sector (EERE, 2022). Examples of collaborative R&D groups include:

- Hydrogen Materials Compatibility Consortium (H-Mat) - Including the study of metals and polymers of interest in hydrogen infrastructure.
- HydroGEN - Addressing advanced water splitting materials challenges in photoelectrochemical, solar thermochemical, and low- and high-temperature electrolytic water splitting.
- Hydrogen Materials Advanced Research Consortium (HyMARC) - Addressing the scientific gaps blocking the advancement of solid-state hydrogen storage materials.

Beyond this, tech and cleantech incubators such as Greentown Labs in Houston provide opportunities for new companies in the space to develop and for companies and individuals to tap into a broad network within the area – these types of incubators can be useful for their ability to foster networks around key technologies and for developing innovations and fostering entrepreneurs.

Universities in the Houston regional area also have a potential role to play beyond research partnerships – helping to develop the employees and innovators of the future hydrogen hub. The training aspect of the collaboration with Academia is being explored by the University of Texas (UT), which is planning to create / set a specialized 101 H2 course. Our interviews with academia indicated increasing requests from students and businesses for more involvement in H2 research.

UT has launched the H2@Scale three-year project, supported by the DOE's Office of Energy Efficiency & Renewable Energy in collaboration with Frontier Energy and Mitsubishi Heavy Industries (MHI) Group. One example of H2@Scale initiative is the development of a demonstration facility at UT - one of the first integrated commercial hydrogen production, distribution, storage and use hubs which will generate carbon-free hydrogen from electrolysis powered by a mix of renewable sources.

Development of joint R&D hubs in the US and Europe is complicated by the fact that H2 research centers haven't really emerged yet, except for the DOE labs such as NREL in Colorado. Schools are just now considering forming research centers to gain access to federal funding. In similar high tech areas, universities such as UT have already demonstrated successful examples of collaboration with industry practitioners, such as the partnership between Samsung and Texas Energy Institute on Silicon Chip manufacturing.

In the long run, a major element many stakeholders were interested in was the development of a large national lab dedicated to hydrogen research within the city's program. There are a number of national labs in the US that are leaders in the space that could establish satellite campuses within the Houston region. Establishing firm relationships with these groups and actionable plans towards bringing these R&D powerhouses into Houston will be critical towards making stakeholders feel supported. These national labs have acted as focal points for research within the US in the hydrogen space, and continue to be both key drivers of innovation, testing facilities for commercial technologies, and essential partners for companies in the broader space as they look to tap into facilities capable of exploring hydrogen manufacturing technologies across the board.

## 5.5. Rate of capital investment

Development of electrolyser manufacturing will require large capital commitments. The requirement for step changes in scale reflects the opportunity but also increases the relative capital risks leading to higher expected



returns, another barrier in achieving cost reductions. The financial disclosures of standalone public companies currently show significant losses, which is likely to be applicable for other Western electrolyzer manufacturers, affecting access to capital.

### **5.5.1. Investment requirements**

Through stakeholder discussions, several investor types expressed keen interest within the sector but had concerns over a lack of familiarity with investments and operating companies. Announcements within the sector show a diverse set of investors participating: venture capital, corporate, accelerators & incubators, and institutional. The nascent status of hydrogen technologies means public incentives are a major factor and capital flows are expected to follow (IRENA, 2022).

The momentum in clean hydrogen projects has been growing annually, with over 500 projects announced in 2021. This translates into 18 MT of eventual supply requiring \$US 95b for the production facilities and a total of \$US 160b including transport and end use infrastructure. However, to hit world hydrogen production targets would require \$US 600b by 2030; a gap of over \$US 500b remains. This investment is attainable – it equates to 15% of O&G investments from 2010-2019 (Hydrogen Council, 2021).

The level of market pre-investment required for large projects means there might be a period where cash flows are insufficient to cover the expectations of financiers. Where hydrogen products are sold into a regulated market there is a greater level of assurance around long-term returns. However, hydrogen in new markets does not have the same demand or price assurance. Policy mechanisms and subsidies assist in bridging these risks and leverage much larger private capital flows. The IRA in the US is one example of providing a backstop to make financial backers feel more secure in their return on investment. A lesser-scaled example in Europe is the public contribution of €26b by InvestEU, which is expected to mobilise €360b of investment by 2027 (IRENA, 2022).

### **5.5.2. Profitability challenges**

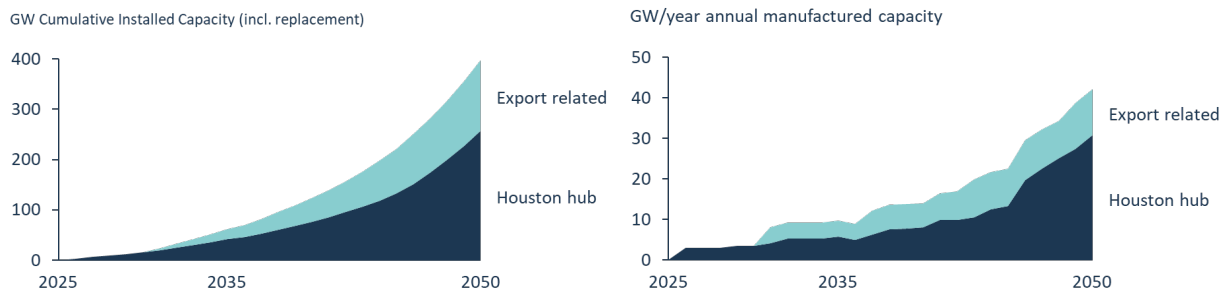
Low-capacity utilization is a prime contributor to current operating losses. Within the approximate 3 GW of global manufacturing capacity only 0.5 GW of electrolyzers was shipped in 2021. Allowing for start-up considerations, a capacity utilization below 35% can still be implied. Thus, cash injections are required for expansion and maintenance of these companies until sales pipelines are established.

At the same time component suppliers seem to be profitable (DeNora electrode business generates 21-23% EBITDA, though hydrogen-related business comprises only small fraction of it). The unit cost of electrolyzers is expected to drop as the industry moves along the learning curve. However, it is not clear how these efficiencies would be split across the supply chain and what their impact on profitability will be.

### 5.5.3. Estimate of Houston hub development

Starting from 2022 forecasted Houston hub hydrogen volumes (HETI, 2022) and assuming Houston is capable of taking a more prominent role in the Liquid fuels synthesis segment which will dominate the US market from 2040 on (USDOE, 2022), we forecast Houston to produce more than 40 GW of electrolyzers per year by 2050 (of which 11 GW for export). Cumulative produced capacity (with replacement) will be close to 400 GW (35% share of US market)

**Figure 44: Houston hub cumulative installed capacity (incl. replacement) and annual manufactured capacity**



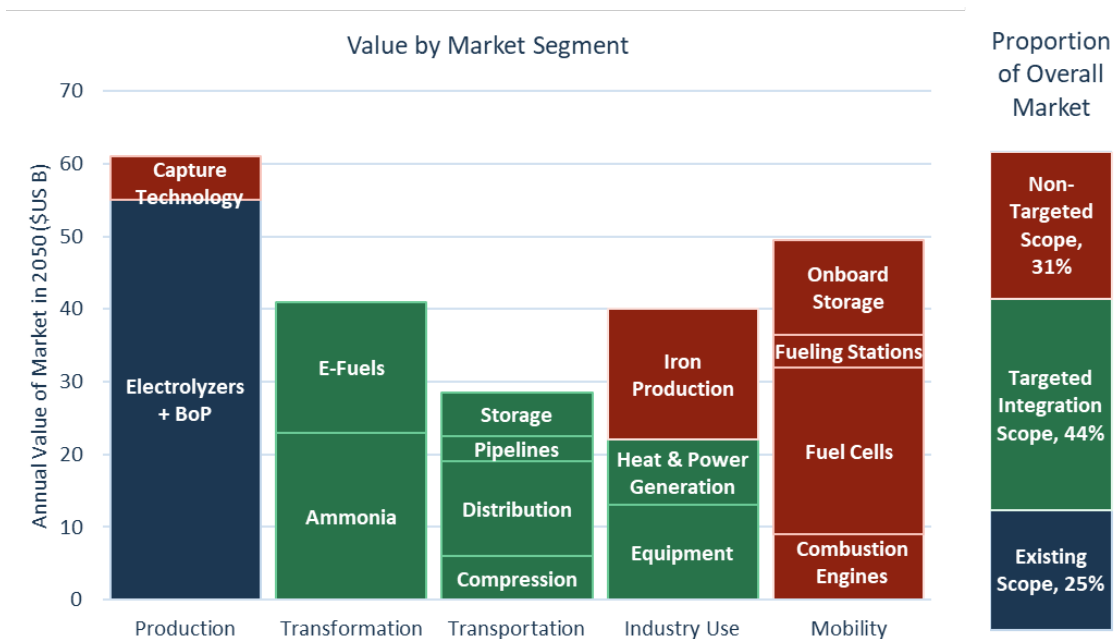
Given expected per unit cost reduction for Houston electrolyzer manufacturing, it will constitute a \$US 30+ billion market by 2050.

## 6. Hydrogen system development and deployment

The overall opportunity related to green hydrogen extends beyond the production of hydrogen facilities. An equally complex challenge is integrating the produced electrolyzers into the overall global energy and resources system. Established electrolyzer producers have recently stated their willingness to ramp up production, but they lack firm commitments from production or demand sources. Orders and funding needs to flow for expansions to occur. There is also concern over having too many orders flowing at once, overwhelming the system and undermining confidence (Parkes, 2022b).

In addition to presenting a roadblock to development, the overall value chain of hydrogen supply represents a multiplier on the value of the electrolyzer facility. Beyond the estimated value of facilities, the projected value of overall system components is shown in Figure 45.

**Figure 45: Projected capital value of hydrogen market components**



Source: (IRENA, 2022b)

The relative value of targeted components within the overall energy system will likely exceed the value of the electrolyzers themselves. It will also exceed other portions of the system not of focus, such as those associated with mobility. Most importantly, the 'integration scope' is essential for unleashing the market electrolyzers are intended to fulfill, representing a 'necessary opportunity'. The related advantages and opportunities of Houston will be explored within this section.

Many of the current and future uses of hydrogen involve its further conversion to chemicals, fuels and materials. Producing and integrating hydrogen in these production processes avoids transport and storage challenges while allowing greater use of existing infrastructure (IRENA, 2022). Refining and chemicals are an important application for scaling up electrolyzers as they provide an existing sizable demand unconstrained by the need to develop other ecosystem elements (renewables production, grid, etc.)

### 6.1. Green versus blue hydrogen

Houston is a global center for downstream O&G processing and development. The current expectation is legacy assets within the Houston area will likely continue to utilize the integrated and over the fence arrangements for hydrogen. Considering recent project announcements, the reductions of carbon intensity of hydrogen within Gulf Coast facilities will be initially achieved through carbon capture additions to existing and new grey hydrogen processes (i.e., blue hydrogen). This is supported by:

- Current and proposed enhancements to CCS subsidies through the 45Q tax credit (WRI, 2022).
- Production Tax Credits from the IRA for lower-carbon hydrogen (up to \$1/kg for hydrogen with 95% reductions).
- Technical and commercial readiness, at scale, of the technology.
- Current perception that blue hydrogen will remain cheaper than green over a long duration.

However, not all industrial processes and locations are suitable for blue hydrogen. As stated by interviewed stakeholders and proposed in several regulations, products directly using hydrocarbon value chains are not acceptable to all users and jurisdictions. As a result, there are applications available where green hydrogen is most feasible or the end user is willing to pay a premium on its use. These include hydrogen used for applications where:

- The primary value chain of produced hydrogen and its products (derivative fuels and chemicals) must be separate from fossil fuels, such as in export to Europe under proposed regulations or in bio-fuels production.
- Natural gas is not available.
- Carbon dioxide offtake and sequestration is not feasible.
- SOEC technology, which is dependent on industrial waste heat for high efficiency.
- Due to other conditions, electrolyzer generated hydrogen is more economic in the near term.

Therefore, Houston Hub needs to ensure a balanced approach and provide incentives for sufficient green hydrogen scale in refining and chemicals. This may be accomplished without the expectation of electrolyzer hydrogen taking over the market in the near term, but that important advancements will occur as it is applied in partnership with industry.

### 6.2. Incentives provided for deployment

Significant policies and funding are being implemented to promote the creation of low carbon hydrogen value chains. The coupling between demand development and electrolyzer equipment development require an understanding of how these developments will impact the choices made by stakeholders and development of the supply chain.

The most dramatic incentive for the development of the low carbon hydrogen market will be provided by the IRA, as discussed in Section 5.4.2.

### 6.3. Large renewable resources with constrained electrical grid access

Within this opportunity, bespoke electrolyzer systems and facilities will be developed to take advantage of abundant renewables available within Texas. It will leverage extensive experience in onshore and offshore construction of facilities, pipelines and electricity transmission in onshore and offshore environments.

Although the utility of hydrogen in decarbonizing industries and economies has been extensively discussed, the availability of renewable power presents a significant challenge to the perspective of generation capacity, generation intermittency and transmission. These challenges are mitigated through conversion of electricity to hydrogen at the point of energy generation through the following benefits (Lyubovsky et al., 2021):

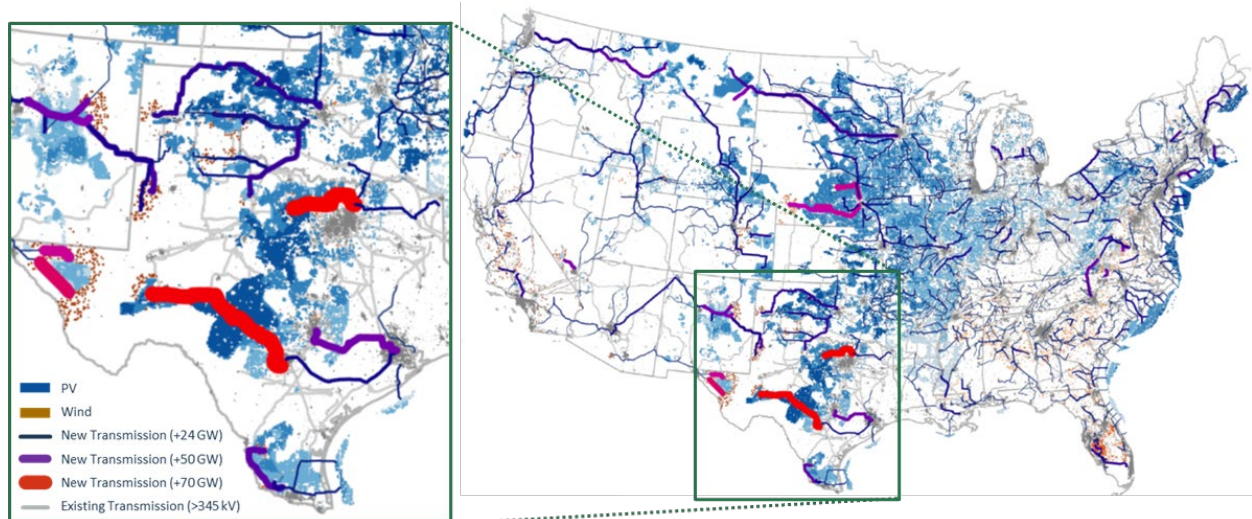
- The amortized transmission costs of hydrogen are estimated to be over 80% less than HVDC on a MWh basis.
- Right of Way (ROW) size, cost, climate vulnerability, and permitting challenges for overhead electrical transmission lines are greater than those of pipelines.

- Hydrogen can be added, extracted for use, converted to e-fuels, diverted to storage or re-converted back to electricity anywhere along a transmission pipeline creating opportunities for arbitrage and grid stabilization. Enhanced regulations will facilitate the integration of electrolyzers in the power system by incentivizing the flexible operation of electrolyzers. Electrolyzers rapid response times can provide services in existing primary, secondary and tertiary grid-balancing markets. If electrolyzers are integrated with the proper supporting regulations and market structures, they will be able to provide these services for additional revenues. Hydrogen can further support power systems through long-term storage and power system firming. Through hydrogen storage, the seasonality of solar, wind and hydropower resources can be compensated. It may provide a further hedge against increasing exposure to unusual weather patterns which affect renewable supply as well as consumer demand (IRENA, 2022).

### 6.3.1. Onshore renewables (wind and solar)

Although wide ranging estimates of the rate of renewable deployment exist, wind and solar developments in Texas are accelerating, giving rise to the challenges stated above. As shown in **Figure 46**, developing large onshore solar and wind resources would require additions of massive transmission capacity, along with offshore wind resources which are expected to be developed by 2050.

**Figure 46: Renewables and transmission development in 2050 under high development scenario**



Source: (Larson et al, 2021)

Meeting 25% of Houston’s 9 million kg/d of hydrogen demand would require an additional 4 GW of additional average electricity demand, or a 20% increase in peak demand and 35% increase in average demand. Options for producing the hydrogen include:

- Providing green electricity from the western portion of Texas using 5 x 345 kV HVAC lines and corridors with local hydrogen production.
- Field conversion of electricity to hydrogen in West Texas followed by pipeline transmission (36-inch diameter, 600 psi).

The estimated relative cost is \$US 0.46 / kg H2 for electricity transmission versus \$US 0.46 / kg H2 for field conversion (Rhodes et al., 2021).

### 6.3.2. Offshore wind

Offshore generation has not progressed as quickly as onshore in Texas, but Houston is well positioned to engage with emerging offshore wind development. This includes the emerging offshore electrolyzer market – Houston’s existing offshore O&G manufacturing industry is well suited to develop infrastructure, repurpose flowlines, and install electrolyzers and compressors on existing platforms.

Offshore wind development has generally focused on areas with water depths <50m, such as the installations in the North Sea. While several US states have bigger offshore wind potential compared to Texas, it is almost entirely concentrated within deep (>60 m) and undeveloped areas lacking suitable port staging facilities. Accessible shallow and transitional areas still have significant (41%) share of the US offshore wind power, and for that segment Texas has the biggest potential among US states (14%, together with adjacent Louisiana – 27%), with other potential hydrogen hubs lagging far behind.

In 2021, a Task Force coordinating renewable energy planning activities on the Outer Continental Shelf (OCS) in the Gulf of Mexico was established (BOEM, 2022). The Bureau of Ocean Energy Management has set a path for conducting a lease sale within the Gulf of Mexico in Q4 2022 (BOEM, 2021). In keeping with previous sales, this should include 1-2 leases of up to 1.5 GW. This will initialize the shallow offshore wind power potential of the Texas Gulf Coast.

Offshore wind coupled with hydrogen is being further developed within a demonstration project led by the University of Houston named, ‘Storing Hydrogen from Offshore Wind Power for Load-balancing and Carbon Elimination’ (Project SHOWPLACE). The project focuses on the Texas Gulf Coast and includes industry, government, public, and academia in establishing the commercial feasibility of synergies between offshore wind power and hydrogen generation and storage (UH Energy, 2022). Key envisioned elements include:

- Re-purposing existing offshore Gulf of Mexico oil and gas platforms and pipelines into green hydrogen hubs.
- Installing floating or fixed (to platform) wind turbines to generate electric power.
- Connection to the onshore electric grid with excess wind power utilized to generate freshwater via desalination and hydrogen via freshwater electrolysis.
- Hydrogen more than demand stored in subsurface geological reservoirs and produced as required.
- Comprehensive roadmap to allow replication of the demonstration project at multiple locations across the Gulf of Mexico.

### 6.4. Globally focused design-build firms support industry conversion

Houston has been a global technical center and headquarters for the O&G industry. This includes high-end executives, scientists and engineers who developed and promoted the industry through past transitions and are pivoting into decarbonisation. The O&G value chains bring imminent and long-term opportunities for the deployment and growth of electrolyzer systems.

These applications occur in physically and technically challenging environments understood by companies already operating in them. The different rates of global implementation mean accelerated solutions need to be initially developed, tested centrally and then deployed globally. Houston is already the hub of this system, with few comparable global peers and none within the hemisphere. These represent premium niche applications with already high costs of supplied energy. As such, they are distinct from other areas of electrolyser applications, representing better margins for companies creating the market. This includes specific areas to be leveraged, as described below.

### 6.4.1. Integration between EPCs and energy firms

Houston is the center for refinery and chemical processing innovation and deployment, with leading firms basing headquarters and regional design-build services in the city, including Jacobs, Fluor, Worley, KBR, Wood, and Bechtel (ENR, 2022). Although each of these companies operates globally, they have the highest global concentration of professional employees in Houston (LinkedIn, 2022).

This innovative, competitive and internationally focused EPC expertise is tightly integrated with energy companies similarly concentrated in Houston (ex. ExxonMobil, Shell, Chevron, Phillips 66, BP, DOW, LyondellBasell). These partnerships yield both incremental and revolutionary innovations in global energy. This will be maintained as electrolyzer technologies are deployed into new and existing facilities globally. This is particularly true within the Americas due to the proximity of Houston to Western Canada, Caribbean, Mexico, Brazil and Chile.

### 6.4.2. Case study – Trinidad and Tobago

A prominent example of integration between EPCs and energy firms can be seen in Trinidad and Tobago's ammonia production. With an output of 4-4.5 Mt/y across 10 facilities, it is the world's third largest ammonia exporter. Trinidad's 1.8 Mt/y of hydrogen demand for methanol and ammonia production accounts for almost half of all Latin American consumption (IEA, 2021).

Natural gas production in Trinidad has declined since 2014, leading to an undersupply of downstream demand and LNG production. As the first industry to face curtailment, the viability of ammonia production facilities in Trinidad is in jeopardy. Yara operates three jointly owned ammonia plants at Point Lisas, which face a deficit of 400 kt H<sub>2</sub>/y, leading to shutdowns over recent years (Yara, 2019).

To compensate for the hydrogen shortfall, NewGen project was launched by Kenesjay Green Ltd. (KGL) to develop a green hydrogen production facility. Using renewable energy from BP Lightsource and waste heat from the existing facility, they will generate dedicated hydrogen to be processed into clean ammonia at the Point Lisas facility. The electrolyzer providers have not yet been determined, although major electrolyser manufacturers have expressed interest. (USEIA, 2022).

Through interviews, the project developers indicated they view Houston as a natural partner for Trinidad. The Yara facility was designed and built by Pullman Kellogg (now operating as KBR), opening in 1981. In 2021 KBR was awarded a study to establish a green hydrogen market in Trinidad and Tobago financed by the Inter-American Development Bank (KBR, 2021). In addition, the design-build for all phases of the Atlantic LNG project was completed by Bechtel from Houston.

## 6.5. Regional participants

There is already a significant number of related efforts and development for green hydrogen that Houston can establish formal collaboration with. This ensure potential opposition and competition is mitigated and larger pooled resources are gained. It may not be successful in all cases, but will help create good neighbors while acknowledging the limits of geography and organizational capacity. This would include the following stakeholders:

- Regional metropolitan areas including Dallas-Ft Worth, Austin San Antonio.
- Energy hubs including Beaumont-Port Arthur, Corpus Christi and Lake Charles.
- Hydrogen development projects and programs including H<sub>2</sub>@Scale (U Texas-Austin), Interstate Highway 45 Zero Emission Vehicle Corridor Plan (NCTCoG).

While located away from current upstream production areas, Houston is a still hub for O&G manufacturing. It coordinates, provides equipment and acts as a central logistics arena to ensure the development of O&G resources throughout the region along within the USA and across the world. This plays to Houston's strengths, and while one city cannot do everything, it can be the focusing point for everything.

As Houston looks to develop as a hydrogen hub, it must take a similar model. The Houston region alone will not be responsible for the majority of regional H<sub>2</sub> production, although it does have local production opportunities.

Significant hydrogen demand in industry, refining and shipping are based out of Corpus Christi, the Gulf Coast and other regional centers while many renewable and natural gas resources for hydrogen production are in West Texas, the Gulf Coast or spread throughout the region. Houston is developing itself as a hub and it needs to have spokes to fulfill its purpose.

It is a natural center for hydrogen equipment manufacturing, logistics management and some degree of production. Houston must coordinate with areas developing as centers of hydrogen production, demand or both to ensure a robust value chain.

Areas such as the Gulf Coast are pursuing opportunities with the DOE to develop a “hub” status, receive federal funding and jumpstart local hydrogen through concentrated funding. They may wish to stand apart from Houston in the short term. However, the DOE and NREL have indicated wishes for funded hubs to merge and collaborative as regional value chains in the long term. Houston will need to reach out and cooperate with elements of the hub to create access for future growth.

Houston and Austin house first class academia facilities such as Universities of Houston and Texas respectively. University of Texas has differentiating depth of expertise in hydrogen research and an extensive network of contacts within the academic community, which is important as this field of study, like the industry itself, is far from maturity and no clear leader has been established. Based on interviews, access to public research within the hub is more important to smaller players, while larger companies with broad product portfolios can leverage existing global links with academia.



## 7. Actions

As stated through this report, Houston provides significant, value driven opportunities for the development of hydrogen electrolyzer manufacturing. Key actions for promoting the establishment and acceleration of a world leading industry are presented in this section. These actions follow from the market status and trends described in Sections 2 to 3 and the expressed needs of stakeholders.

Although every stakeholder has a list of actions required for their own success, the actions are focused on what actions CHF should pursue. Each action represents a significant effort requiring dedicated resources, planning and execution. The highly dynamic environment requires an adaptive approach and actions are described so they remain relevant throughout the build-out of the electrolyzer industry in Houston. Each area of action includes a summary of the needs and the actions responding to them with accompanying discussion.

### 7.1. Secure critical materials

Securing critical materials will ensure the future supply needed to allow unconstrained growth for market participants is met. Existing and new supply chains will require adjustment to meet the accelerated production of electrolyzers. This involves critical materials whose availability promotes or constrains innovation and deployment. The key needs and actions are outlined in [Table 6](#).

**Table 6: Actions to Secure Critical Materials**

Need	Actions
Critical Materials Needs and Availability	Conduct modelling that projects requirement for components and materials in hub market. Express interest in contributing to national critical materials security initiatives.
Balance of Plant Component Supply	Initiate and maintain supply chain health checks for critical components imported from outside area (ex. power supply).
Advanced carbon materials	Develop strategy for establishing graphite and graphene manufacturing in Houston. Develop strategy for establishing carbon fiber materials manufacturing in Houston for use in hydrogen storage.
Platinum and iridium supply	Develop strategy for establishing Platinum Group Minerals processing / recycling facility in Houston.

## 7.2. Establish industrial zones

The establishment of industrial zones for electrolyzer manufacturing with a strong competitive value proposition, R&D critical mass and clear incentives builds upon Houston’s existing strengths and leverages the massive existing capacities. The key needs and actions are outlined in **Table 7**.

**Table 7: Actions to Establish Industrial Zones**

Need	Actions
Strengthen connections between existing players	<ul style="list-style-type: none"> <li>• Map logistics between existing suppliers and proposed industrial zones identifying where resources can be targeted.</li> <li>• Determine relevant skillsets desired by manufacturers and compare to local training capacity.</li> </ul>
Bring players into local manufacturing	<ul style="list-style-type: none"> <li>• Identify and engage with top targets for stack assembly.</li> <li>• Identify and engage with top targets for membrane electrode assembly (MEA) manufacturing.</li> </ul>
Promote effective incentives	<ul style="list-style-type: none"> <li>• Create alignment on ideal package of incentives to be requested at each level of government.</li> <li>• Benchmark package of incentives to other hubs for qualifying hydrogen equipment manufacturing and production activities.</li> <li>• Evaluate if subsidies for green hydrogen are sufficient to level the incentive with other energy transition initiatives (such as 45q applied to blue hydrogen).</li> </ul>
Communicate standard components needed	<ul style="list-style-type: none"> <li>• Set standards for components across the value chain to promote recognition and interchangeability with existing products.</li> <li>• Issue challenges communicating mismatches between available and required component specifications.</li> <li>• Create document to identify how IP concerns will be addressed within collaborations.</li> </ul>

## 7.3. Establish foundational projects to stimulate demand

Focus on locally developing the high impact, high value portions of the hydrogen equipment supply chain through stimulating demand. The key needs and actions are outlined in **Table 8**.

**Table 8: Actions to establish foundational projects to stimulate demand**

Need	Actions
Expand applied research and development	<ul style="list-style-type: none"> <li>• Progress discussions with NREL regarding establishing R&amp;D facility in Houston.</li> <li>• Establish testing and certification facilities for existing and developed BoP products in conditions encountered in hydrogen generation.</li> <li>• Identify industrial facilities willing to host commercial scale pilots.</li> </ul>
Promote foundational infrastructure projects	<ul style="list-style-type: none"> <li>• Determine renewable energy available for grid connected electrolyzers in Houston.</li> <li>• Progress concept for hydrogen pipeline and storage connections to west Texas.</li> </ul>

Need	Actions
Backstop early orders	<ul style="list-style-type: none"> <li>• Develop demand backstops for hydrogen supply within local chemical and refining industries.</li> <li>• Provide guarantees for initial projects.</li> <li>• Further explore role of government as client.</li> </ul>
Promote foundational export projects	<ul style="list-style-type: none"> <li>• Initiate discussion with EU hubs to establish Houston as a hydrogen export candidate.</li> <li>• Explore connections to generation markets outside of Texas (Trinidad, Chile, etc.).</li> </ul>

#### 7.4. Stakeholder and investor engagement and communication

The hub will proceed only with the support of the stakeholder and investor community. This requires deliberate actions to build acceptance and momentum with local stakeholders as well as the investment community. Houston O&G legacy leads to initial perceptions for supporting transitions. It also left Houston with a significant incumbent SMR capacity, which coupled with an abundance of formations suitable for carbon storage has given rise to blue hydrogen proposals that may further overshadow efforts at establishing green hydrogen in the short term. The key needs and actions are outlined in **Table 9**.

**Table 9: Actions to enhance stakeholder and investor engagement and communication**

Need	Actions
Promotion of suppliers	<ul style="list-style-type: none"> <li>• Approach existing companies to identify, map, and inventory existing facilities to be retrofitted into hydrogen value chain manufacture.</li> <li>• Create public directory of existing services and suppliers.</li> </ul>
Establish regional connections to gain critical mass	<ul style="list-style-type: none"> <li>• Include Regional metropolitan areas including Dallas-Ft Worth, Austin, San Antonio.</li> <li>• Include Energy hubs including Beaumont-Port Arthur, Corpus Christi, and Lake Charles.</li> <li>• Include regional Initiatives and Hydrogen development projects already underway.</li> </ul>
Capacity and Cost tracking	<ul style="list-style-type: none"> <li>• Track deployments / production of hydrogen systems by type, capacity, and production within Texas (or commission data from market services company).</li> <li>• Promote price index for Hydrogen traded in Houston.</li> <li>• Prepare strategy for progression into hub pricing data for electrolyzers and marketed hydrogen.</li> </ul>
Communicate with local community	<ul style="list-style-type: none"> <li>• Communicate opportunity to business and local community.</li> <li>• Publish surveys showing current level of business and local community support.</li> <li>• Expand web-based communication on hub status and participants.</li> </ul>

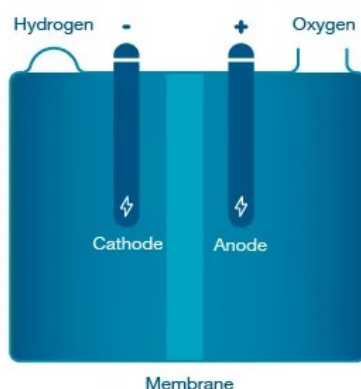
# Appendices

## Appendix A - Green hydrogen technology

A basic description and understanding of the complex components of the different electrolyzer technologies provides a basis for assessing the value chain and subsequent strategies. The following section describes these aspects from a techno-commercial perspective.

Electrolysis uses electricity to drive a reversed, non-spontaneous chemical reaction. Though there are many types of electrolysis, we focus on hydrogen electrolysis from water (and use the term to only apply to this reaction). Hydrogen electrolysis is driven by hydrogen electrolyzer systems and are favoured as key contributors to the energy transition. At their core, they add electricity to water ( $H_2O$ ) to form hydrogen and oxygen. This reaction does not happen naturally. The electrolysis reaction is the core process and requires an electrolyzer, as shown in **Figure 47**.

**Figure 47: Diagram of generic water electrolyzer**



Source: (Cummins, Inc., 2020)

The electrolyzer technology involves a cathode, anode, and membrane placed together in a cell. Multiple cells are placed together to form a stack, and multiple stacks can be placed together to form a larger integrated unit. Applying electric current to these stacks forms ions (typically  $H^+$  or  $OH^-$ ) which move through a liquid or solid membrane electrolyte between the electrodes. Hydrogen bubbles form on the cathode side of the membrane and oxygen gas at the anode side while a membrane or diaphragm prevent their mixing. These gases are then extracted and stored (IRENA, 2020).

There are a variety of electrolyzer technologies, each with unique attributes and levels of development. They are generally divided into a few different types, which are described within this section.


### Electrolyzer technologies

Four major technologies considered as the core of green hydrogen. These are Proton Exchange Membrane Electrolyzers (PEM), Alkaline Electrolyzers (AE), Solid Oxide Electrolyzer Cells (SOEC), and Anion Exchange Membrane electrolyzer (AEM) technologies. All of these follow the central electrolyzer system tenet of water being split into hydrogen and oxygen when electricity is added. However, the technologies and materials used, the energy required, their capital cost, and their commercial scaling vary widely.

Though details on these technologies will be provided, the basic details are:

- ALKALINE is the oldest technology, the most scaled, and the least expensive. It requires very inexpensive parts, but also frequently has a high space footprint and can struggle with low-capacity factors. Newer versions may overcome this.
- PEM has emerged due to prices have fallen to levels similar to alkaline. It requires more complicated manufacturing than alkaline and frequently uses rare materials (e.g., platinum and iridium), though manufacturers are trying to find ways to shift away from them. It has good performance at low load factors, which has made it popular with intermittent renewable sources.
- SOEC are scaling from laboratory to commercial levels as numerous manufacturers pursue them. They have very high energy conversion efficiency and the materials used are not rare, but operate at high temperatures and are generally sold at high price points due to complications in design to manage heat degradation.
- AEM electrolyzers are still a nascent, primarily laboratory technology that brings the efficiency of PEM without the need for rare noble metals. They still have significant issues with degradation and cost that must be overcome but are viewed as a major potential avenue for electrolyzer scaling due to low base costs for components.

### Alkaline

Alkaline electrolyzers	
	<p>Efficiency: 60 – 78 kWh/kg H<sub>2</sub>                      Cost (2021 USD): \$300-700/kW                      Minimum load factor: 20-40%</p>
Key Materials	Nickel, potassium hydroxide
Notes	<ul style="list-style-type: none"> <li>• Mature technology</li> <li>• Common Materials</li> <li>• Currently lowest cost</li> <li>• Lower efficiency</li> <li>• Higher minimum load factor</li> </ul>
Future Planning:	<ul style="list-style-type: none"> <li>• Planned megaproduction electrolyzer manufacturers in India and China are betting on alkaline technology</li> <li>• Cheap materials are an advantage, though load factor may prove problematic for renewables</li> </ul>

The basic elements, as shown in **Figure 48**, include:

- Functions using a reaction in water and a liquid electrolyte solution (alkaline) such as potassium hydroxide or sodium hydroxide.
- When current is applied to the cell stack, the hydroxide ions (OH<sup>-</sup>) move through the electrolyte from the cathode to the anode of each cell, with hydrogen gas bubbles generated on the cathode side of the electrolyzer and oxygen gas at the anode.

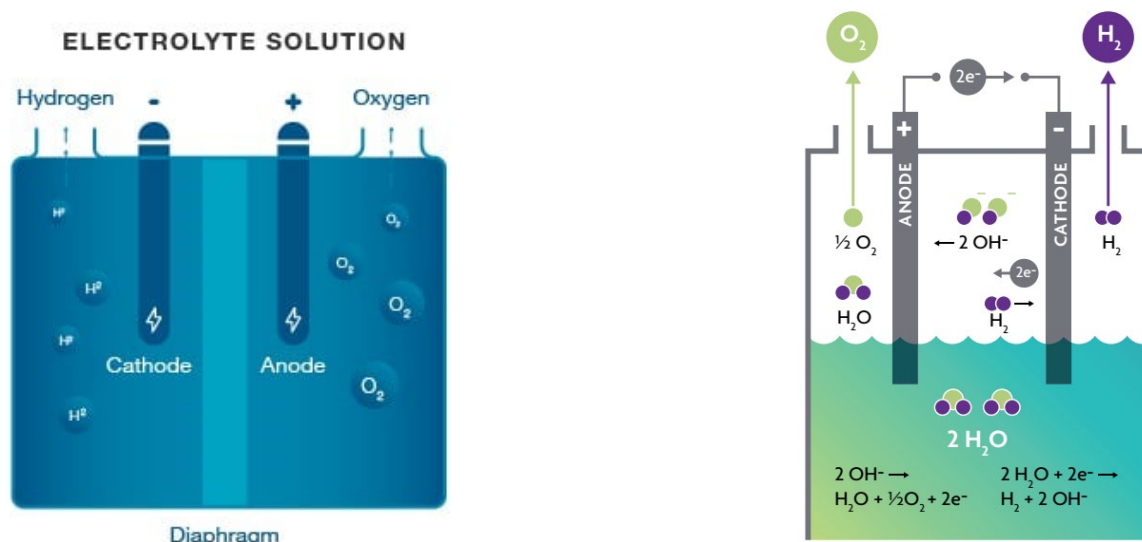
Key opportunities:

- Older, reliable technology with almost no use of rare materials means supply chain considerations or materials access are less of a concern.
- Lowest cost compared to other technologies.

Key Risks:

- Alkaline has lower efficiency compared to the other electrolyzer technologies and requires larger amounts of space – some advanced alkaline manufacturers state these issues are being overcome with new technologies.
- Many of the oldest, least expensive Alkaline technologies are being brought up to scale in China and other countries with low manual labor costs. While new alkaline technologies show greater efficiencies, better capacity factor ranges, and lower footprints than older ones, the ability of Chinese manufacturers to outcompete on pure price economics is unknown, and some already forecast Chinese dominance of the alkaline electrolyzer market (Collins, Chance is high that China will take over global hydrogen electrolyser market in similar way to solar sector: BNEF, 2022).
- Validation of ability to operate at high current densities with nonnoble cathode coatings (e.g., Raney Nickel or Ni-oxides). These coatings have a long history in the chlor-alkali industry, where they have shown their durability at current densities of up to 0.6 A cm<sup>2</sup>. There are no fundamental electrochemical limitations that would make these coatings unsuitable for operation at higher current densities, but there will likely be a negative impact on their lifetime. If the lifetime turned out to be insufficient, more-advanced coatings based on noble metals can be used as an alternative (ISPT, 2022).
- Durability of the stack components at an operating temperature of 100 °C, which is higher than of present-day systems (ISPT, 2022).

Figure 48: Basic diagrams of an alkaline cell and reactions



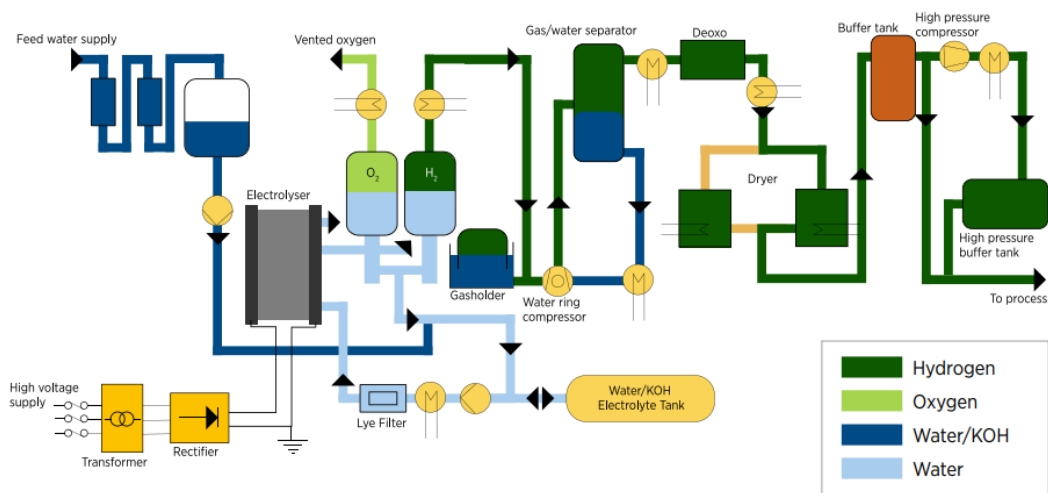
Sources: (Cummins, Inc., 2020), (Cockerill, 2021)

Alkaline use a high concentration liquid alkaline electrolyte (potassium hydroxide [KOH] solution in most cases) with a porous separator (generally ZrO<sub>2</sub>) between the anode and cathode and nickel-coated stainless steel for electrodes. Hydroxide ions cross the separator via the liquid solution to form oxygen and water on the anode side and hydrogen with hydroxide ions on the cathode side.

Intermixing of hydrogen and oxygen in the electrolyte reduces the ability to operate at higher pressure levels. To prevent this, thicker (0.252 mm) diaphragms are used which creates a higher resistance and lower efficiencies. Spacers are included by some manufacturers between electrodes and diaphragms to further avoid the intermixing of gases. These thick diaphragms and added spacers result into high ohmic resistances across the two electrodes, drastically reducing current density at a given voltage. Advanced designs, using smaller gap electrodes, thinner diaphragms, and new electrocatalysts, have improved performance (IRENA, 2020).

Alkaline has a simple stack design, is relatively easy to manufacture, is the oldest, most industrially advanced, and (currently) cheapest electrolysis technology. Classic alkaline designs are known to behave very reliably, reaching lifetimes above 30 years. Generally, they have a higher power consumption compared to PEM electrolysis and require a larger space footprint (up to 10x larger, in some cases, with large electrode areas). Their maturity and use of inexpensive materials and simple manufacturing has made them popular for mass scaling in China and India. As shown in **Figure 49**, the unique elements of alkaline require recirculating the electrolyte around the stack and separating the electrolyte from the gases produced with gas-water separators. The water column within the separator can act as a buffer for changing load specifications. A mixing pipe is needed to balance the OH<sup>-</sup> charge consumed between anode and cathode, which makes the stack difficult to operate at high pressures (this is why alkaline generally has lower efficiency than PEM). Higher pressure is possible through specialized configurations and equipment; this impacts the traditionally low-cost and highly reliable design but has been considered a key element of advanced alkaline competing with PEM (IRENA, 2020).

**Figure 49: Generalized alkaline full balance of plant design**




Source: (IRENA, 2020)

Numerous manufacturers point to the use of new chemistries and composite technologies as achieving greater efficiency and reducing space footprint for alkaline electrolyzers making them more competitive.



PEM

Proton exchange membrane (PEM) Electrolysers	
	<p>Efficiency: 50 – 83 kWh/kg H<sub>2</sub></p> <p>Cost (2021 USD): \$500-700/kW</p> <p>Minimum load factor: 5-15%</p>
Key Materials	Platinum, iridium, titanium, scandium, yttrium
Notes	<ul style="list-style-type: none"> <li>• Low minimum load factor makes it ideal for intermittent renewables</li> <li>• High efficiency of production</li> <li>• Lowest square meter footprint</li> </ul>
Future Notes:	<ul style="list-style-type: none"> <li>• Reliance on rare materials may limit scaling</li> <li>• Research on alternative materials to supplant platinum is ongoing</li> <li>• Some future possibility (potential AEM route) due to load flexibility</li> </ul>

Basic elements, as shown in **Figure 50**:

- PEM electrolyzers use a solid polymer electrolyte for their reaction in an acidic solution, which requires the use of non-reactive metals such as platinum and iridium.
- Water splits into hydrogen and oxygen when current is applied on the cell stack; the hydrogen protons pass through the membrane to form H<sub>2</sub> gas on the cathode side.

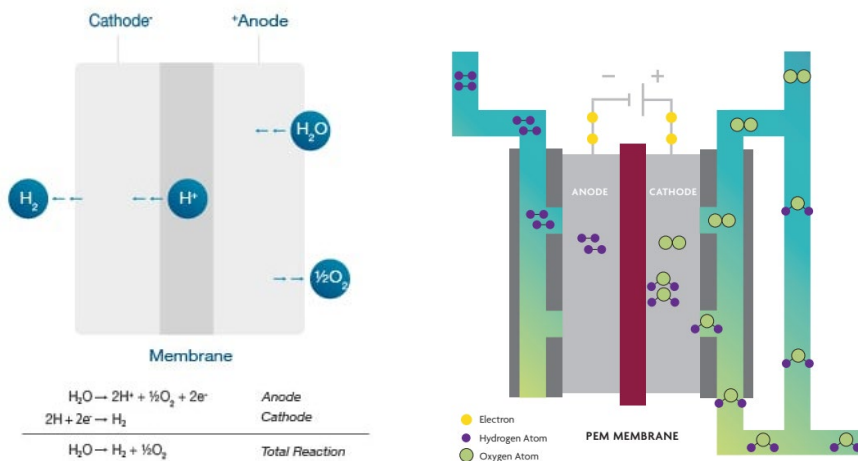
Key Opportunities:

- Provide greater conversion efficiency (electricity to hydrogen) compared to alkaline.
- High pressure operation with more efficient liquid phase compression.

Key Risks:

- Most technologies require use of rare metals such as platinum and iridium to function in the acidic PEM system – these are expensive components.

**Figure 50: Basic diagram of a PEM cell and reaction**



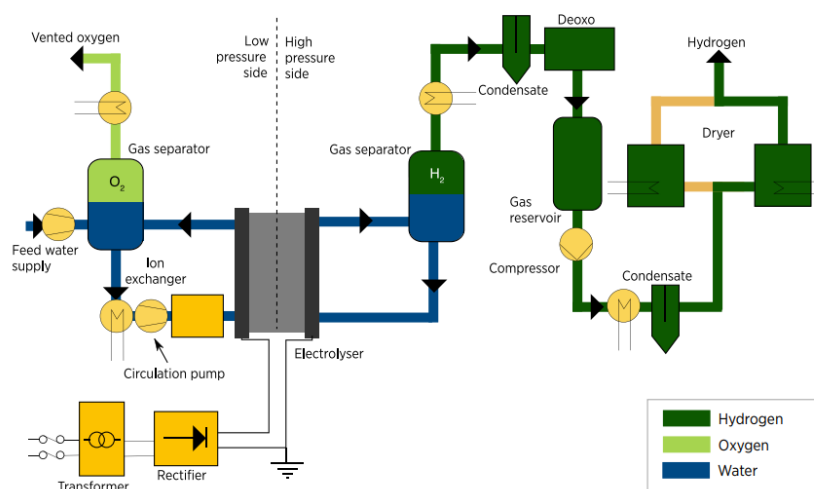
Source: (Cummins, Inc., 2020), (Cockerill, 2021)

PEM technology utilises a solid polymer electrolyte membrane and an applied current to separate hydrogen (via protons) and oxygen from water. The electrons are then transported from the anode electrode to the cathode electrode via the electrical circuit. The electrons combine with protons to create hydrogen molecules (Cockerill, 2021).

In a proton exchange membrane (PEM) electrolyser, the proton (H+) is transported through the PEM in a highly acidic environment, which requires platinum group metals (PGM) as catalysts and titanium bipolar plates to survive the highly corrosive conditions. These materials make the PEM more expensive but improve its efficiency. The necessity for noble metals is the driving supply chain worry for PEM technologies, but as companies look to scale, they are focusing on automation and proprietary coating technologies as a method for reducing the cost of PEMs by reducing reliance on these materials.

As shown in **Figure 51**, on a technical level, PEM systems have fewer parts than Alkaline (even if they cost more overall), which reduces system complexity and maintenance costs. PEM systems also have choices in terms of unit pressure: atmospheric, differential, or balanced – the right system for a particular use. The anode side uses pressure control/monitoring, circulation pumps, and heat exchangers. The cathode side needs a gas-separator, a gas dryer, and a compressor. (IRENA, 2020)

**Figure 51: Generalized PEM full balance of plant design**



Source: (IRENA, 2020)


The advantages of PEM technology are:

- Electrolysis has a fast response ramp-up and ramp-down capability, as well as a wide dynamic operating range of 0-100% – making it ideal for generating hydrogen using excess renewable energy.
- Compact - require as much as 10x less space space than alkaline counterparts, though this varies by manufacturer.
- Reliable, and low maintenance operation makes PEM suitable for small-to-medium industrial applications and off-grid operations.
- Synergies with PEM fuel cells and the ability to capitalise on advancements in materials and processes already being implemented at scale.

Numerous manufacturers we interviewed spoke about PEM technology having advantages with advanced automation and proprietary coating systems, which have made it less ideal for scale up in China and other countries relying on availability of less-expensive manual labor. As PEM electrolyzers are generally more energy and space efficient in hydrogen production while operating at lower capacity factors than alkaline counterparts, it

will become a question of which economics and space considerations favor one technology over another on particular sites, or potentially a mix of both.

**SOEC**

Solid oxide electrolyzers	
	<p><b>Efficiency:</b> 45 – 55 kWh/kg H<sub>2</sub>  <b>Cost (2021 USD):</b> \$1500-2000/kW  <b>Minimum load factor:</b> 0-10%</p>
<b>Key Materials</b>	Scandium, yttrium
<b>Notes</b>	<ul style="list-style-type: none"> <li>• Highest available conversion efficiency</li> <li>• No commercial projects right now</li> <li>• Highest cost currently</li> <li>• Requires high temperature (800-1000C for operation, resulting in material degradation)</li> </ul>
<b>Future Notes:</b>	<ul style="list-style-type: none"> <li>• Can operate as either electrolyzer or fuel cell, raising potential for some storage applications</li> <li>• Theoretically low minimum load factor is limited by temperature requirements – must bring unit up to operating temperature</li> </ul>

Basic Elements, as shown in **Figure 52:**

- Electrolyte/membrane is made of solid ceramic material (see diagram below).
- Electrons combine with water at the cathode to form hydrogen gas and oxygen ions, which pass through the membrane and react at the anode to form oxygen gas.
- SOEs operate at a much higher temperature (800-1000C) than other electrolyzer types – this gives them the capability to be more efficient in electricity use.

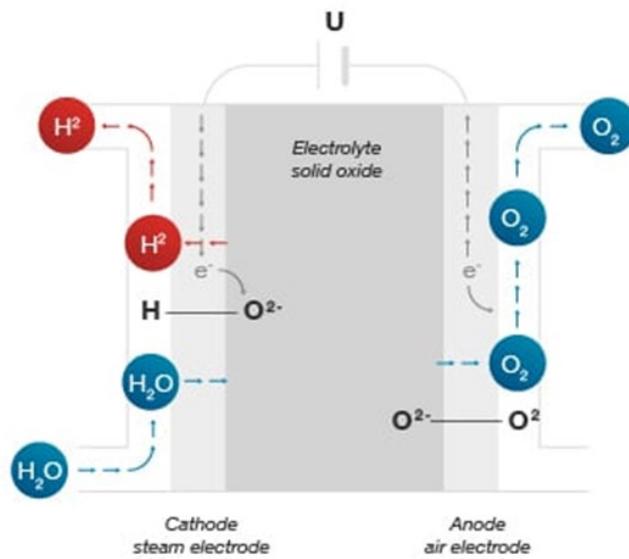
Key Opportunities:

- High efficiency cuts down on operating costs for electrolyzers, which may result in larger operational cost reductions for green hydrogen manufacture.
- High temperature requirements create the possibility of running SOEs as part of “cogeneration” at industrial or other high temperature sites to take advantage of existing heat energy.

Key Risks:

- Need for SOEs to be designed for extreme temperature conditions and use – currently high price premium for SOEs (2-4x alkaline and PEM price points). Manufacturers working to bring these to scale will determine long-term commercial pricing.
- Component durability at high temperatures can be an issue.
- SOECs have not been manufactured at mass deployment level and will need to have manufacturing methodology scaled appropriately.
- Generally require some rare-earth materials such as scandium and yttrium, but these are not supply constrained under current systems.

Figure 52: Basic diagram of an SOEC



Source: (Cummins, Inc., 2020)

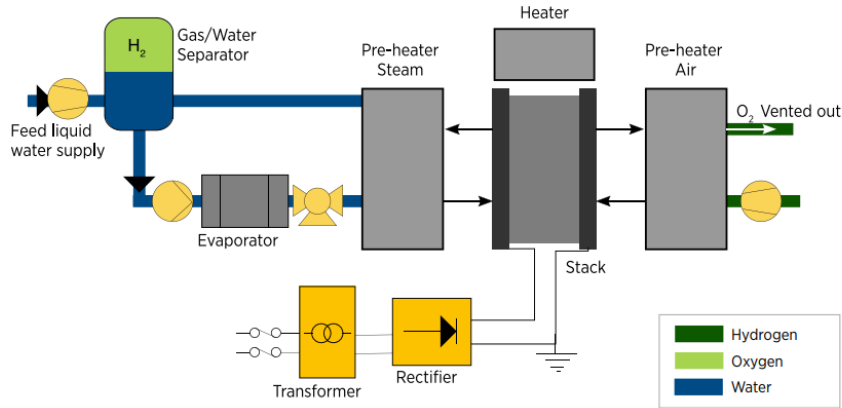
Electrons from the external circuit combine with water at the cathode to form hydrogen gas and negatively charged ions. Oxygen then passes through the solid ceramic membrane and reacts at the anode to form oxygen gas and generate electrons for the external circuit.

This reaction occurs at high (800-1000°C) temperatures. This high temperature allows for the use of cheaper nickel electrodes and replaces electricity demand with heat demand (decreasing renewable power demand and allowing the use of SOEC for “cogeneration” waste heat at industrial sites). Some SOECs can be reversed to operate as fuel cells, though manufacturers have pointed out that units are often optimized for either production or consumption or another – this is unlikely to be a standard practice. SOEC can also allow co-electrolysis of CO<sub>2</sub> and water to produce syngas, an extremely useful element for synfuels and chemical components.

This high temperature cycling often leads to part degradation and lifetime issues. Stack degradation may occur as seals, piping, and interconnects struggle with high temperature production scaling – SOEC can work better with more consistent demand and less frequent shutoff/start-up, though they are capable of operating at low load factors. Overall SOEC are a premium-priced, extremely efficient technology for green hydrogen production, but is still developing out of the ‘lab level.’ Showcasing it has overcome its degradation issues and what the price-point would be for mass scaling (IRENA, 2022).

As shown in **Figure 53**, SOEC systems are arguably the simplest in terms of parts, though the parts are operating in a very high-temperature environment. One reason for the interest in SOEC has been their space and electricity efficiency, and their ability to be tied to sources of waste heat (SOECs coupled with thermal solar plants are considered a strong economic possibility) (IRENA, 2020).

Figure 53: Generalized SOEC full balance of plant design



Source: (IRENA, 2020)

AEM

Anion exchange membrane (AEM) Electrolyzers	
	<p>Efficiency: 55 – 69 kWh/kg H<sub>2</sub>                      Cost (2021 USD): \$700-1000/kW                      Minimum load factor: 5-15%</p>
Key Materials	Nickel, steel
Notes	<ul style="list-style-type: none"> <li>Low operating temperature/pressure</li> <li>No commercial manufacturing (lab scale only now)</li> <li>Require less water filtration</li> </ul>
Future Planning:	<ul style="list-style-type: none"> <li>Lower space footprint than alkaline – similar to PEM – gives some advantages</li> <li>AEM lifetime is now an issue – components degrade quickly</li> <li>Needs further work in lab, but may hold potential in long-term</li> </ul>

Basic Elements, as shown in Figure 54:

- Functions using a reaction in water and a liquid electrolyte solution (alkaline) such as potassium hydroxide or sodium hydroxide.
- When current is applied to the cell stack, the hydroxide ions (OH<sup>-</sup>) move through the electrolyte from the cathode to the anode of each cell, with hydrogen gas bubbles generated on the cathode side of the electrolyzer and oxygen gas at the anode.

Key opportunities:

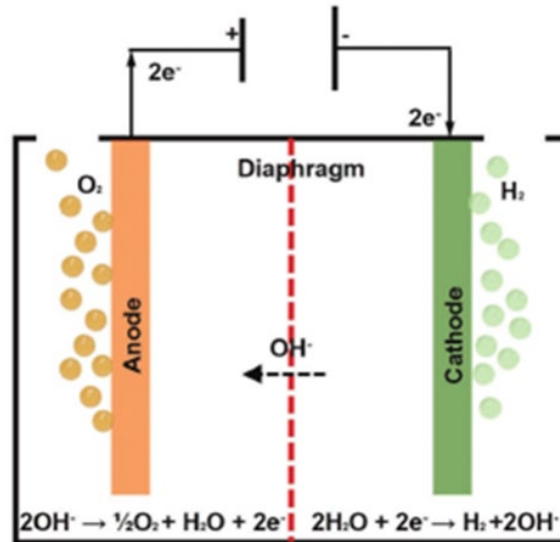
- Older, reliable technology with almost no use of rare materials (though nickel prices have been rising) means supply chain considerations or materials access are less of a concern.

Key Risks:

- Many of the oldest, least expensive alkaline technologies are being brought up to scale in China and other countries with low manual labor costs. While new alkaline technologies show greater efficiencies, better capacity factor ranges, and lower footprints than the older ones, the ability of Chinese manufacturers to outcompete on pure price economics is yet unknown, and some already forecast Chinese dominance of the alkaline electrolyzer market (Collins, 2022).

- Validation of the ability to operate at high current densities with nonnoble cathode coatings (e.g., Raney Nickel or Ni-oxides). These coatings have a long history in the chlor-alkali industry, where they have shown their durability at current densities of up to 0.6 A cm<sup>2</sup>. There are no fundamental electrochemical limitations that would make these coatings unsuitable for operation at higher current densities, but there will likely be a negative impact on their lifetime. If the lifetime turned out to be insufficient, more-advanced coatings based on noble metals can be used as an alternative (ISPT, 2022).
- Durability of the stack components at an operating temperature of 100 °C, which is higher than that of present-day systems (ISPT, 2022).

Figure 54: Basic diagram of an AEM

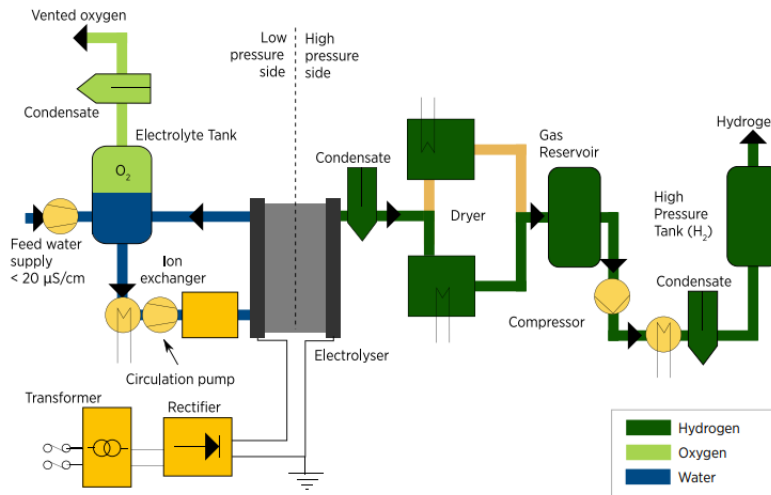


Source: (Yan, 2020)

AEM electrolyzers are currently only at lab or pilot scale and have not reached widespread commercialization. Theoretically, AEM technology combines the benefits of PEM and alkaline systems by achieving space and energy conversion efficiency comparable to PEM technology, while allowing the use of non-noble catalysts (no need for platinum, titanium, or iridium). Today, commercially available membranes lack sufficient stability in alkaline which have limited the widespread adoption of AEM in electrolysis applications as it leads to uncertain lifetimes. AEM is considered a technology with massive potential as the world looks to green hydrogen scaling. It combines the less harsh environment of alkaline electrolyzers with the efficiency of a PEM electrolyser and ability to operate under differential pressure. Though theoretical performance is high, in practice efficiency is not terrific due to low AEM conductivity, poor electrode architectures, and slow catalyst kinetics. AEM electrolyzers must develop membranes more capable of charge density achieve the high efficiencies and low costs the system promises (IRENA, 2022).

As shown in **Figure 55**, AEM systems are extremely similar to PEM systems in overall plant design. As this is a technology still in laboratory development, it is difficult to comment on the major opportunities for change, other than the continued difficulty of the membrane degradation coupled with the KOH environment (IRENA, 2020).

Figure 55: Generalized SOEC full balance of plant design

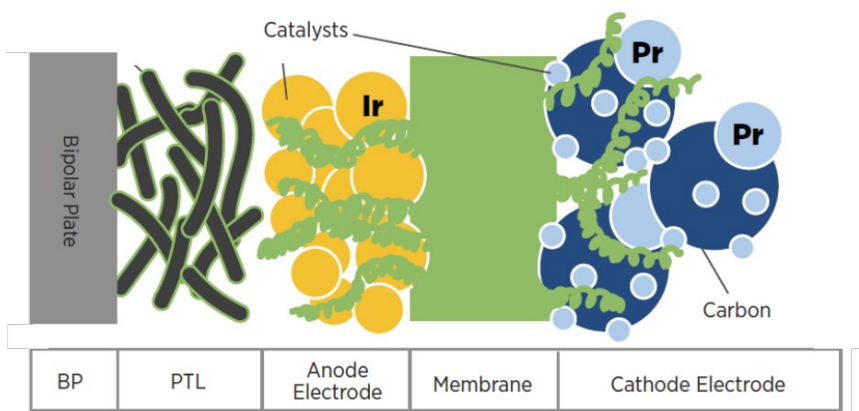


Source: (IRENA, 2020)

### Electrolyzer cell materials

The electrolyzer cell is the core component and process of the electrolyzer facility. Although they vary significantly between technologies, the typical layers and materials of a cell are shown in **Figure 56**. The key components are further described in the following sections.

Figure 56: Electrolyzer cell composition



Source: (IRENA, 2022)

Recent assessments found the US and Asia were leaders in cell components and the processed materials used in them. The electrolyzer industry (and PEM in particular) has benefitted from progress in R&D and supply chain development in fuel cells, and this trend is expected to continue. The supply chain of these materials includes large companies producing components which are a small part of a broad business, smaller companies with specialized capabilities, and manufacturers producing a wide variety of the components. However, none of these companies have current capacity to produce at the high rates required to meet projected requirements (USDOE, 2022).

### Bipolar plates (BPP)

Within the cell, the bipolar plates provide the mechanical support and distribute the flow. The water reaches the electrodes by flowing through the bipolar plates. Bipolar plates are the thickest, pure metal components in an

electrolyzer stack, highly contributing to weight. Bipolar plates in a stack must be made of corrosion-resistant materials suited to the application, as shown in **Table 10** (IRENA, 2020).

**Table 10: Bipolar plate materials in different electrolyzer technologies**

Type	Anode Material	Cathode material
Alkaline	Nickel coated stainless steel	Nickel coated stainless steel
PEM	Platinum coated structured titanium plates or Titanium coated stainless steel	Gold coated structured titanium plates or Carbon fibre
AEM	Nickel coated stainless steel	Nickel coated stainless steel
SOEC	None	Cobalt coated stainless steel

BPP are typically manufactured using compression moulding for composite plates or spray coating of stamped metal plates. Alternative manufacturing processes with potential quality and economic advantages include hydroforming, additive manufacturing, and etching/machining (Mayyas & Mann, 2019). On the hydrogen side, carbon composite materials have potential, but the use of a single-layered titanium sheet as bipolar plate is more cost-effective (Fraunhofer ISE, 2021).

The BPP manufacture is expected to be manufactured close to the site where cell assembly occurs. This is currently dominated by Europe and Asia, but there is an opportunity to migrate manufacturing to the US. There is an extensive market for fuel cell bipolar plates and many producers are extending product offering to electrolyzers. Both broad metalwork portfolio companies (such as Mitsubishi Power, Schunk, Feintool, Elcon or Dana) and hydrogen focused specialists (Graebener, Hycco) are present on the global market.

### Porous Transport Layers (PTL)

The PTL is a key stack component enhancing water diffusion and the splitting reaction. It ensures uniform distribution of the electric current between the bipolar plate and the electrodes. To fulfill this role, it needs high electrical and thermal conductivity combined with gas and water permeability. The material varies to suit the conditions of the technology, but typical materials are listed in **Table 11** (IRENA, 2020).

**Table 11: PTL materials in different electrolyzer technologies**

Type	Anode PTL Material	Cathode PTL Material
Alkaline	Nickel mesh (not always used)	Nickel mesh
PEM	Platinum coated sintered porous titanium	Platinum coated sintered porous titanium or carbon cloth
AEM	Nickel foam	Nickel foam or carbon cloth
SOEC	None	None

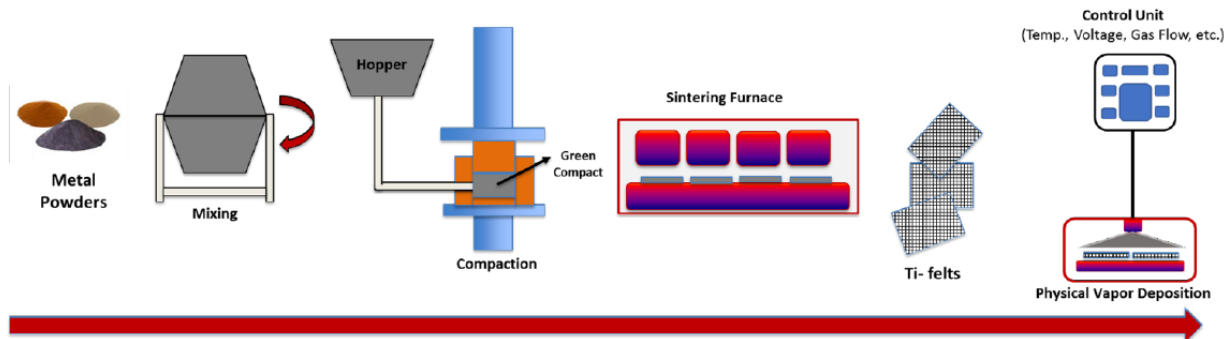
Notably, PTL layers in PEM cells require special materials and coatings to prevent oxidation in the acidic environment and to provide optimal interface resistance. The platinum loading may be optimised, and substitute compositions are the subject of R&D, but use is currently considered unavoidable. A typical process for manufacturing of titanium-felts used in the PTL is shown in **Figure 57**, which includes:

- Mixing titanium powder with adhesive powder and lubricants.
- Compaction of mixture into brittle titanium particles.
- Sintering (partial melting) within a furnace to form felts.



- Precious metal coating.

Figure 57: Powder metallurgy process for producing titanium based PTL



Source: (NREL, 2019)

### Electrode assembly

The electrode assembly is composed of layered materials which are the most protected intellectual property and define the different electrolyzer types. The membranes/separators are chosen for high strength, high efficiency, high oxidative stability, dimensional stability with change of temperatures, good durability and high ion conductivity. Typical materials are listed in **Table 12**

Table 12: Electrode assembly materials in different electrolyzer technologies

Type	Catalyst - Hydrogen Side	Membrane / Separator	Catalyst – Oxygen Side
Alkaline	Nickel coated perforated stainless steel	ZrO <sub>2</sub> stabilized with PPS mesh	Nickel coated perforated stainless steel
PEM	Platinum or platinum alloys on carbon metal oxides	PFSA (Nafion™)	Iridium, ruthenium, or their alloys
SOEC	Nickel-YSZ	Ytria-stabilized Zirconia	Perovskite-type
AEM	High surface area nickel	Divinylbenzene (DVB)	High surface area Nickel or NiFeCo alloys

Sources: (IRENA, 2020) (USDOE, 2022).

Within PEM, the electrodes are directly coated on the membrane, forming the membrane electrode assembly (MEA). There are two predominant methods of manufacturing a MEA: catalyst coated membrane (CCM) and gas diffusion electrode (GDE) manufacturing (Blagoeva et al, 2020). Currently R&D is focused on reducing of catalyst loadings. The catalyst layers on both the anode and the cathode are only a few micrometers thick. Iridium is a critical raw material that contributes costs and potential bottlenecks in an expanded PEM industry (Fraunhofer ISE, 2021).

The producers of membrane materials tend to be very large companies with these materials making up a very small portion of their overall business (e.g., Dow, 3M, DuPont). PFSA membranes are used for both fuel cells (e.g., in vehicles) and electrolyzers, and their demand will depend on the uptake of both. Currently, PFSA consumption is similar for both, but demand is expected to increase dramatically within USDOE projections with electrolyzer demand dominating (USDOE, 2022).

The major PFSA brands used for PEM electrolyzers are Nafion by Chemours (DuPont spin-off), Fumapem by Fumatech-BWT Group, Flemion by AGC Chemicals, Aquivion by Solvay and Aciplex by Asahi Kasei; other manufacturers include Dongyue Group and Gore.

Nafion membranes (Nafion 115, 117, and 212) seem to dominate the market due to higher current densities, high durability, high proton conductivity and good mechanical stability.

All major producers have their manufacturing locations in the US – in Delaware (Gore) and Pennsylvania (Ion Power, Chemours distributor), NJ (Solvay), North Carolina (Chemours).

**Gaskets**

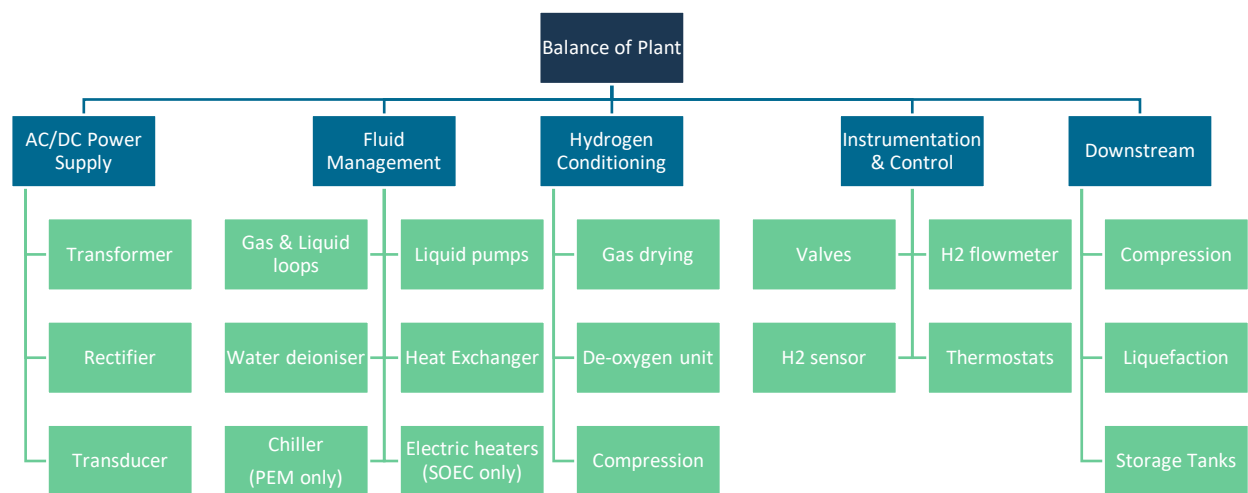
Bipolar plates electrolyzers are enclosed with gaskets, which could be vermiculite based, vitreous glass and mica gaskets. So far electrolyzers are niche yet quickly developing segment for gasket manufacturers, which cater mostly to O&G, pipeline, energy industries. In principle Alkaline and PEM stacks are not as challenging applications, and automotive seal manufacturers are readily able to pivot into this market. Much of gasket business is driven by specifications, and specs for green hydrogen systems applications are still wide open.

Establishing production in Houston would need to include opening a new sheet line, which requires the purchase of a calendaring machine (about a \$US 5M investment). Given a lead time of approximately 6 months, gasket manufacturing could be up and going within a year.

**Key balance of plant components**

Electrolyzer facilities have several common BoP components as well as components that are specific to particular electrolyzer facilities. As shown in **Figure 47**, BoP components may also vary within proprietary designs and according to engineering design decisions. Their configuration within an Alkaline system is shown in **Figure 48** and within a PEM system is shown in **Figure 50**.

**Figure 58: BoP components**



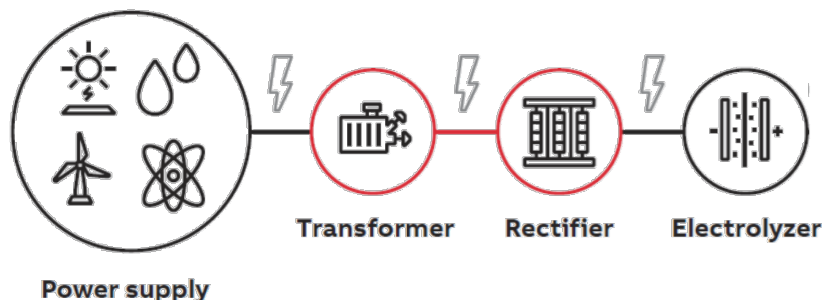
These components perform critical functions within electrolyzer facilities and represents the highest potential for near term cost performance compared to electrolyzer stacks, which may require longer term R&D development (IRENA, 2020).

Most descriptions, efficiency, and cost calculations of electrolyzer systems exclude downstream operations storage and compression. They are described briefly below while the more complex, liquefaction process is excluded.

### Power supply

The power supply system ensures sufficient electricity is supplied to both stacks and BoP elements, while minimizing its own power losses. The basic elements of the necessary power system are shown in **Figure 59**.

**Figure 59: Basic elements of electrolyzer power system**



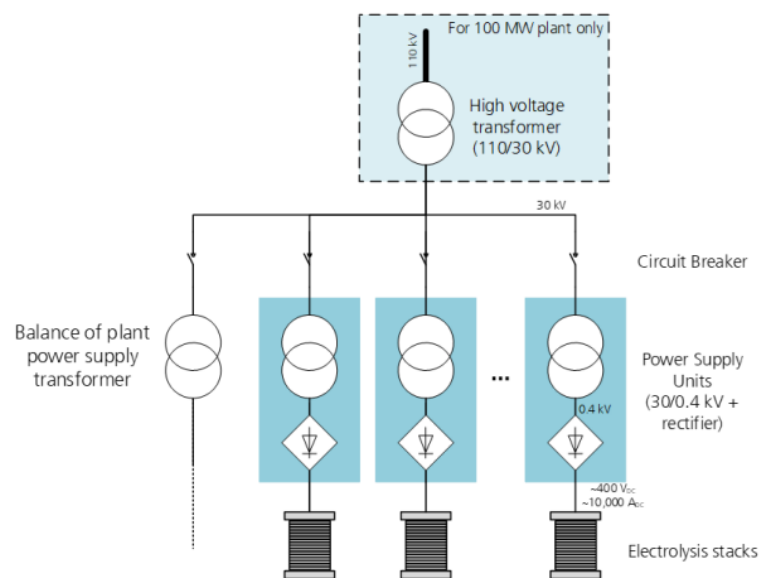
Source: (ABB, 2021)

The power system needs to be connected to a suitable HV grid level to fulfil the maximum plant capacity:

- Plants with capacity under 10 MW are usually connected to mid-voltage grid (20-30 kV).
- Larger plants (ex. 100 MW) would usually be connected to the high-voltage grid (110 kV).
- GW scale plants are connected to the transport grid (380 kV).

Electricity grids typically operate at high voltage alternating current (AC). In the initial conversion process, voltage is reduced within a transformer. In the following process the power is converted to direct current (DC) in a rectifier (typically thyristor-based). The low voltage DC power is supplied to the electrolyzer. As shown in **Figure 60**, a single transformer system may supply an array of rectifiers and electrolysis stacks.

**Figure 60: Power supply for a system with several electrolysis stacks**



Source: (Fraunhofer ISE, 2021)

Within small scale plants the power supply units and rectifiers are typically provided within the modular package where large facilities may require customized designs from EPC contractors for bespoke systems. Where large

trains are used the power supply system may be standardized using utility scale components. The power supply complexity is also driven by the degree of flexibility required to accommodate varying input power and output product rates.

Rectifiers are a key component of the power supply with the greatest restriction for turn-down capability as their efficiency degrades rapidly below 20% load. To achieve overall space and cost efficiency, rectifiers operate with several stacks. This is an optimisation as it also reduces the overall system flexibility.

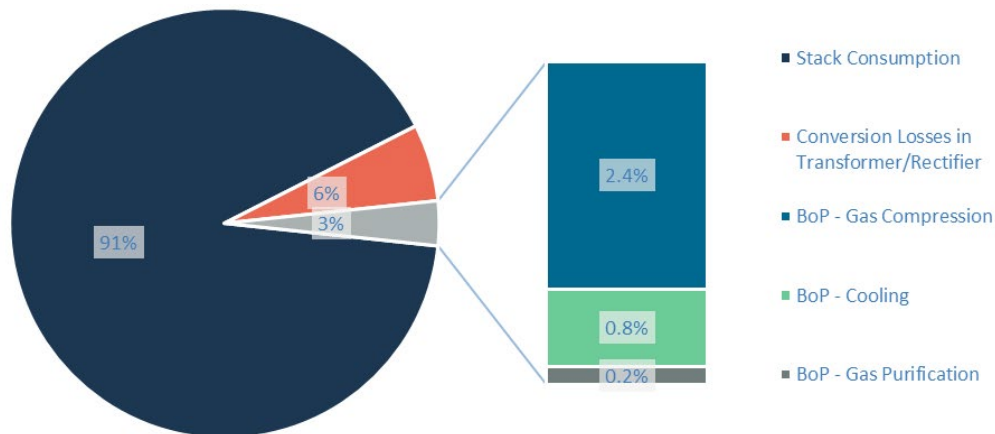
The following additional considerations apply to power system (Fraunhofer ISE, 2021):

- Stack voltage depends on the number of cells and the nominal cell voltage at rated load and is in the range of several hundred volts.
- The stack current depends on the current density (1.7-2.1 A/m<sup>2</sup>) and the cell area.
- Degradation of electrolysis cells leads to higher cell voltage with increasing operation hours.

To produce the rated amount of hydrogen even with degraded stacks, the stack voltage needs to be increased so the output voltage window of the rectifiers must include the minimum voltage of the electrolysis stack at start-of-life and partial load, as well as the maximum voltage of the stack at end-of-life at full load.

Typically, approximately 90% or less of input power is delivered to the electrolyzer, as shown in **Figure 61**. Power losses occur within the transformer and to a greater degree in the rectifier. The rectifiers have their own low-voltage transformer for internal supply. Power is also drawn from the supply for BoP at various points according to the power requirements of the associated equipment.

**Figure 61: Energy flows (simulated) within begin of life electrolyzer system**



Source: (Fraunhofer ISE, 2021)

There are three segments of the suppliers, of which the first two are prospective candidates to take part in the hub supply chain ecosystem:

- US manufacturers including Honeywell, Dynapower, Neeltran-AMSC.
- International companies including ABB, Hyundai, Toshiba, Bharat Heavy Electricals, GE, Siemens, Mitsubishi, Schneider Electric.
- Chinese manufacturers.

### Fluid management

Water is the key reactant and high-purity feed water is required for the process. Poor water quality is one of the main reasons for stack failure for PEM electrolyzers. Many elements are quickly affected due to impurities such as membrane, ionomer in the catalyst layer, catalysts, and PTLs. Contaminated feed water can poison and deactivate catalysts, leading to higher cell voltages and lower efficiency, and ultimately reduced plant life.

The water purification unit reduces the conductivity ( $\mu\text{S}/\text{cm}$ ) of the feed water through a series of processes. The required water conductivity is defined by the manufacturer and electrolyser process. For most systems, the following requirements apply:

- Feed water conductivity of max.1  $\mu\text{S}/\text{cm}$  according to ASTM D1193-99e1 Type II.
  - PEM electrolysis especially can require lower conductivities ( $<0.1 \mu\text{S}/\text{cm}$ ).
- Total dissolved solids  $<0.5$  ppm.

In many locations the facility will be connected to a water utility, which typically is 100-1,000  $\mu\text{S}/\text{cm}$ . The use of seawater (with up to 42,000  $\mu\text{S}/\text{cm}$ ) and wastewater is also possible but requires more extensive treatment. The water treatment system will tend to be centralised for larger, modular systems rather than having a separate unit for each stack (Fraunhofer ISE, 2021).

Following treatment, the feed water pump(s) increase the water pressure to the pressure of the anode side and feeds it to the process. The water treatment systems used are mature technologies that have widely distributed providers, particularly within heavily industrialised regions.

### Hydrogen conditioning

The hydrogen exiting the electrolyzer requires further processing for subsequent applications or for storage. This includes additional unit processes for drying and removal of entrained oxygen including (Fraunhofer ISE, 2021):

- Demister - coalescent filters to retain fine droplets of liquid.
- Deoxidizer reactor - oxygen removal is performed based on a palladium catalyst which reacts residual oxygen with hydrogen.
- For fine drying, pressure swing or preferably temperature swing adsorption is used.

Where the produced oxygen stream is also collected for use, additional and similar treatment may be required. The pressure rating and associated cost of these processes must match the system pressure. These systems are mature technologies that have widely distributed providers, particularly within heavily industrialised regions.

### Control system

Digital technology implementation is primarily motivated by general business productivity, reliability, and safety. The advantages of a digital strategy with an underlying asset management system are a broad topic. However, increasing the connectivity of equipment, grid energy status and cost, and demand signals specifically provides opportunities for increasing whole system efficiency. This is increasingly important during the current changes in the energy system where all these components are increasingly dynamic.

Enhanced operational efficiency can be achieved automatically or through an advisory system where suggested operational adjustments are displayed, and operators can choose whether to implement them. The monitoring is ideally implemented at the level of the whole system, distribution nodes, process units, and main equipment. Artificial intelligence techniques are applied to the monitored data, other relevant conditional data, and efficiency indicators to design a forecasting model.

These techniques can also be used for condition monitoring where longer-term drift from performance is detected. This prompts minor or major maintenance events to provide optimal efficiency performance. This enhances standard practices where maintenance is performed at set intervals.

While smaller facilities will come with onboard controls, the additional complexity of a large system with multiple stacks requires one unified control system for the complete plant. Control systems are mature technologies while additional instrumentation and data management may be elective. Artificial intelligence is established but has specific room for advancement, particularly under new applications like GW scale electrolyser systems.

Accordingly, there would be multiple local providers available.

## Storage

Depending on the system, hydrogen from the electrolyser is conventionally between atmospheric pressure and 30 bar (where pressurized electrolyzers are used). Delivery to consuming processes, storage, liquefaction, or pipeline export requires further compression. A barrier to hydrogen storage and distribution is its low volumetric energy density, meaning that hydrogen needs to be compressed or stored in liquid form.

At the smaller scales of current electrolyzer and transport fueling systems hydrogen is stored in cylinders. The types of vessels are shown in **Table 13**. Currently the costs of the vessels increase with types, but with advancements in carbon fiber and manufacturing they could eventually reduce below metal cylinders. These vessel definitions apply to both stationary and mobile (trailer mounted) vessels.

**Table 13: High pressure gaseous hydrogen storage vessel types**

Type	Materials of construction
Type I	Metal tank (steel/aluminum) Approximate maximum pressure, aluminum 175 bars, steel 200 bars
Type II	Metal tank (aluminum) with filament windings like glass/carbon fibre around the metal cylinder Approximate maximum pressure, aluminum/glass 263 bars, steel/carbon 299 bars
Type III	Tanks made from composite material, fibreglass, or carbon fibre with a metal liner (aluminium or steel) Approximate maximum pressure, aluminum/glass 305 bars, aluminium/ carbon 700 bars
Type IV	Composite tanks such as carbon fibre with a polymer liner (thermoplastic) Approximate maximum pressure 700 bars

Sources: (USDOE, 2022), (Blagoeva et al, 2020)

Produced hydrogen can be stored at scale through (IRENA, 2020):

- Compressed storage in steel tanks - Typical pressures are 700 to 1000 bar with a volume reduction of 600x.
- Compressed storage in underground reservoirs (ex. salt caverns) – Typical pressures are 100 to 275 bar at large scale.
- Liquefied storage in steel tanks - More complex compression is required for liquefaction and storage at -253°C and pressure below 5 bar but achieves volume reductions of 870x.

As an alternative, emerging technology, nanomaterial hybrids could make hydrogen storage more economical and compact. Suitable metal alloys can react with hydrogen reversibly to form metal hydrides at moderate pressure and temperature, maintaining reactivity and capacity over many cycles.

## Compression

For the compression of hydrogen in large-scale applications, reciprocal, multi-stage compressors are typically used including compression to storage, transmission, or in cryo-compression (Fraunhofer ISE, 2021). Hydrogen compression is a mature technology and widely used for process applications in refineries and petrochemical facilities.

Most compressors used for gaseous hydrogen compression are either positive displacement compressors or centrifugal compressors. Positive displacement compressors can be reciprocating or rotary while reciprocating compressors use a motor with a linear drive to move a piston or a diaphragm back and forth. This motion compresses the hydrogen by reducing the volume it occupies. Reciprocating compressors are most commonly used for applications requiring a very high compression ratio. Rotary compressors compress through the rotation of

gears, lobes, screws, vanes, or rollers. Hydrogen compression is a challenging application for positive displacement compressors due to the tight tolerances needed to prevent leakage.

Centrifugal compressors rotate a turbine at very high speeds to compress the gas. Hydrogen centrifugal compressors must operate at tip speeds 3 times faster than that of natural gas compressors to achieve the same compression ratio because of the low molecular weight of hydrogen. Centrifugal compressors are used in H<sub>2</sub> applications where flow is relatively high and the pressure head low (Hall, 2022). Specifically designed turbomachinery addresses these challenges by using a larger number of compression stages and/or high impeller operating speeds (Brun et al, 2020).

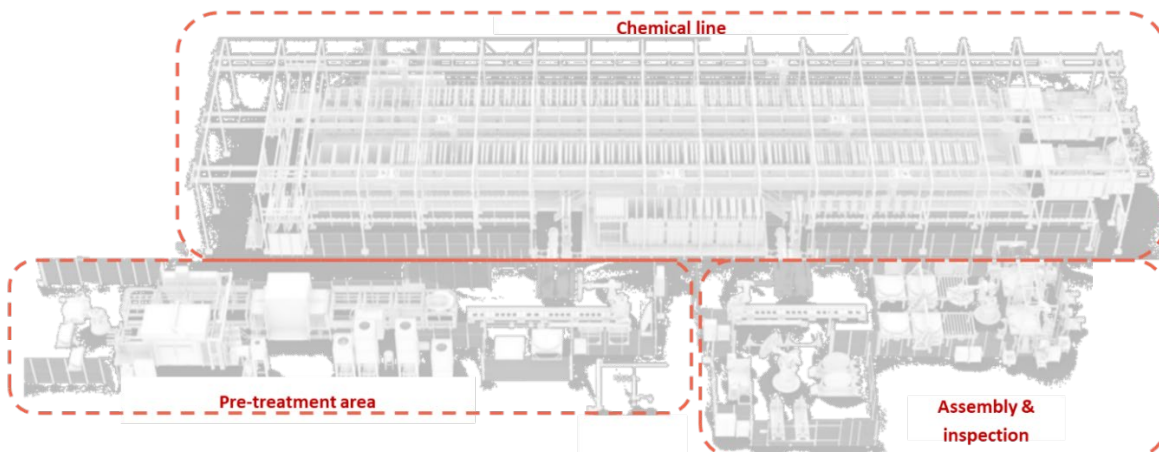
High levels of compression need to be accomplished in multiple stages to limit the hydrogen outlet temperature after each stage. Compression systems are available in a wide range of capacities, starting from drive powers in the single-digit kW range and ending up in the two-digit MW range. The compressor stages are usually powered by an electrical motor. These units are available from several vendors.

Some of the major hydrogen compressor manufacturers include both conglomerates (Siemens Energy, Mitsui, Nash - part of Ingersoll Rand), as well as more specialized players like Howden, Ariel (Ohio), Neuman & Esser, Burckhardt, and Sundyne.

### Integration facilities

A typical electrolyzer manufacturing plant with 1 GW capacity has footage of 12-15 thousand m<sup>2</sup>. As a relatively compact facility, a 1 GW plant employs one to two hundred production staff (according to Nel and ITM Power). Apart from the assembly area (which in case of alkaline electrolyzers may take minor share of area), it may include some upstream operations, as per the example in **Figure 62**.

**Figure 62: Process flow and outline of 300 MW/yr. Alkaline electrolyzer manufacturing facility**



Source: (Nel, 2021)

## Appendix B - Multi-Criteria Analysis methodology

The following section describes the methods by which the relative strengths and areas for enhancement have been identified. Both qualitative information and quantitative data were collected as the basis for a Multi-Criteria Analysis (MCA). The MCA process and inputs and results are described within this section.

### Evaluation criteria

In MCA, evaluation criteria are used as metrics against which the performance of the alternatives being evaluated are measured. In this case the criteria have been applied against Houston and competing markets. Criteria must be exhaustive and mutually independent to promote rational insights consistently identify strategic strengths and weaknesses. The criteria are classified into five categories representative of key areas of consideration, including:

- Demand – Represents the current market and future growth in low carbon intensity hydrogen consumption.
- Facility Build – Conditions are conducive to the establishment of hydrogen electrolyser equipment manufacturing.
- Supply Chain – Availability and competitiveness of labor and components contributing to H2 electrolyzer facilities.
- R&D – Presence of supportive environment for continued advancement of technology and skillsets.
- Policy & ESG – Enabling overall regulations, practices, and conditions for corporate performance.

As shown in **Table 14**, each of these categories has a large set of criteria that contribute to the overall performance.

**Table 14: Evaluation categories and criteria**

Category	Criteria	Detail
Demand	Refining and chemicals	Hydrogen use in refining and chemicals
	Seasonal storage	Seasonal storage of hydrogen for energy system stabilization
	Marine shipping	Hydrogen use in marine fleets / international shipping
	Onshore renewables	Hydrogen generation coupled with onshore renewables
	Heavy haul trucks	Hydrogen use in heavy/long haul trucks
	Steelmaking	Hydrogen use in steelmaking
	Offshore wind	Hydrogen generation coupled with offshore wind
	Light vehicles	Hydrogen use in passenger / commercial vehicle fleet
	Electrolyzer export	Providing electrolyser systems to domestic and international markets outside Texas
Facility Build	Local incentives	Ease and incentives of establishing and growing a business. Availability of local /state level economic support and incentives.
	Federal funding	Availability of Federal funding in Hub
	Investor attractive	Confidence that industrial and private equity investment in facilities will achieve financial and energy transition results and provide capital funding
	Business migration	Electrolyser manufacturers currently willing to relocate or build new facilities in location
	Industry conversion	Facilities and infrastructure currently committed to the hydrocarbons value chain will be converted to manufacture of electrolyser component, modules, and systems
	Permitting ease	Ability to get facility development and construction permits in a straightforward and on-time process
	Build capability	EPCM and Modular Construction
	Capital cost	Capital cost of establishing facility (land, construction, commissioning)
	Export terminals	Terminals and export facilities for export of hydrogen products (ex. Ammonia)
	Economies of scale	Transition to economies of scale will yield a competitive position for production



Category	Criteria	Detail
Supply Chain	Renewable power	Virtual renewable power purchases will facilitate the establishment of electrolyzers
	Logistics facilities	High-capacity multi-modal logistics and transport facilities
	BoP components	Availability and cost impact for facility BoP components
	Service hub	Area will form a service hub for maintaining deployed electrolyser fleet in region
	Learning curve	Integrated economy able to accelerate learning curve and achieve cost reductions
	Machines and equipment	Availability and cost impact of machines for electrolyzer facility components
	Critical materials	Availability and cost impact for critical materials (ex. PGM, carbon fibre)
	Skilled labor market	Existing locally based and skilled labor market
	Labor cost	Cost competitiveness of labour market
	Labor migration	Ability to attract talent to region
	Labor stability	Stable labour market
	Project dealmaking	Center of dealmaking for the integration of electrolyser facilities into fossil fuel and petrochemical supply chains
R&D	Deployment mindset	Fit-for-industry mindset (as opposed to perpetual R&D cycles)
	Automation	Integration of automation into manufacturing
	Standards	Establishing an organization to develop fit-for-purpose standards and certifications for systems and components for equipment interoperability
	IP security	Companies able to protect current and future intellectual property and trade secrets
	Industry collaboration	Existing collaborative relationships between industry and institutions
	DoE connection	Ability to connect closely to DoE resources
	Institution profile	World class research and development facilities and institutions present
Policy and ESG	Carbon pricing	Economy wide carbon pricing
	Safety practices	Safe practices and culture within industry
	Community support	Support and recognition from local community as an economically important industry
	Economic development	Economic opportunities will accrue across the hub, particularly assisting disadvantaged communities and promoting Diversity, Equity, and Inclusion outcomes
	Industry reputation	Reputation of corporate practices within market
	Climate risks	Exposure to climate risks
	Foreign competition	Protection from unlimited foreign competition in domestic electrolyzer market
	Green H2 market share	Ability to gain green electrolyzer market share versus other low carbon hydrogen types
H2 pricing hub	Existing hub pricing mechanisms within market will be extended to green hydrogen and related products	

### Scoring scheme

A scoring scheme was developed and applied to each of the evaluation criteria using a 7-point scale. The performance measurement is translated into a normalized ordinal scale to allow quantitative and qualitative criteria to be evaluated against a common reference as the basis for ranking. The scoring scale was defined for each of the criteria relative to maximum and minimum extents of performance or best and worst case. Examples of performance criteria are shown in **Table 15**.

**Table 15: MCA performance criteria**

Score		Performance Category			
		General	Likelihood of success	Demand	Risk exposure
Large disadvantage	1	> 50% Decrease	No possibility	No available market, no foreseeable prospects	High chance of uninsurable incident erasing several years profitability or ceased operations
Medium disadvantage	2	> 20% Decrease	Very Limited	Highly Distributed, small applications with low technology maturity, low growth	Larger exposures where incident results in long period of lost operations
Small disadvantage	3	> 5% Decrease	Limited	Limited market, challenging or delayed deployment (10-20 years)	Larger exposure but insurable and recoverable operations
Neutral	4	± 5%	Moderate certainty	Large overall market with development rate limiting deployment, distributed and mid scale applications	Exposure within the boundaries of normal business management capabilities
Small advantage	5	> 5 % increase	Above moderate, firm evidence / commitment	Large Market eventually topping out but large deployment gap to fulfill	Regular business exposure with quick recovery
Medium advantage	6	> 20 % increase	Highly certain, some instances already	World leading market with deployment within 5 years, some technology development required	Slight exposure with very small effects
Large advantage	7	> 50 % increase	Highly Certain, frequently occurring already	World leading scale with immediate deployment potential, large point source uses	No exposure

**Criteria importance**

Although the criteria used are intended to be mutually exclusive and exhaustive, they are not all equal in importance. The relative importance of criteria is indicated in literature and by stakeholders both by the frequency with which they are raised and the importance that it is assigned when discussed. Importance is the second dimension that is used for determining the overall materiality of a criteria and is applied as according to the scale described in **Table 16**.

**Table 16: Criteria importance**

Score	Stakeholder and overall perceptions	
Negligible	1	Indication that factor is not considered
Very Small	2	Acknowledged but immaterial most of the time
Small	3	Acknowledged as potential driver but not normally or currently a factor
Small to Medium	4	Consistently present but minor / secondary driver
Medium	5	Acknowledged as a factor that is balanced with others in this range
Medium to High	6	Acknowledged as a factor that is balanced with others, potential to become high
High	7	Indicated as highly motivating by several stakeholders, consistent prominence. Clear evidence of materiality provided in research and literature

## References

- CHEFCIISA. (2021). *China Hydrogen Energy & Fuel Cell Industry Development Report 2021*. China Hydrogen Energy & Fuel Cells Industry Innovation Strategic Alliance.
- ABB. (2021). *High Power Rectifiers for Hydrogen Production*. Sweden: ABB.
- Akbilgic, O., Doluweera, G., Mahmoudkhani, M., & Bergerson, J. (2015). A meta analysis of carbon capture and storage technology assessments: Understanding the driving factors of variability in cost estimates. *Applied Energy*, pp. 11-18.
- Arizona State University. (2021). *Doing Business North America*. Tempe: Arizona State University - Center for the Study of Economic Liberty.
- Baker Hughes. (2022). *Energy transition*. Retrieved from Baker Hughes: <https://www.bakerhughes.com/energy-transition>
- Blagoeva et al, D. (2020). *Materials dependencies for dual-use technologies relevant to Europe's defence sector*. Luxembourg: Publications Office of the European Union. doi:doi:10.2760/977597
- BloombergNEF. (2020). *Green hydrogen: time to scale up*.
- BloombergNEF. (2021). *1H 2021 Hydrogen Market Outlook*. Tengler, Martin.
- BOEM. (2021). *Offshore Wind Leasing Path Forward 2021–2025*. Washington D.C.: Bureau of Ocean Energy Management. Retrieved from <https://www.boem.gov/sites/default/files/documents/renewable-energy/state-activities/OSW-Proposed-Leasing-Schedule.pdf>
- BOEM. (2022, 06 24). *Gulf of Mexico (GOM) Intergovernmental Renewable Energy Task Force Meetings*. Retrieved from Bureau of Ocean Energy Management: <https://www.boem.gov/renewable-energy/state-activities/gulf-mexico-gom-intergovernmental-renewable-energy-task-force#:~:text=Established%20last%20year%2C%20the%20Task,in%20the%20Gulf%20of%20Mexico>.
- Bristowe, G., & Smallbone, A. (2021). *The Key Techno-Economic and Manufacturing Drivers for Reducing the Cost of Power-to-Gas and a Hydrogen-Enabled Energy System*.
- Brun et al, K. (2020, 12). Special Report: Hydrogen Compression - Hydrogen Compression. *Turbomachinery International*, pp. 22-24.
- Buckley, K. (2020, April). *Thousands Of Oil And Gas Workers Have Been Laid Off In Houston. What's Next?* Retrieved from Houston Public Media: <https://www.houstonpublicmedia.org/articles/news/energy-environment/2020/04/29/368266/whats-next-for-thousands-of-laid-off-oil-and-gas-workers-in-houston/>
- businesswire. (2022, April 12). *Strategic Acquisition of Future Industrial-Scale Green Hydrogen Production in the Caribbean*. Retrieved from Bussinesswire - A Berkshire Hathaway Company: <https://www.businesswire.com/news/home/20220411005925/en/Strategic-Acquisition-of-Future-Industrial-Scale-Green-Hydrogen-Production-in-the-Caribbean>
- CHEFCIISA. (2021). *China Hydrogen Energy & Fuel Cell Industry Development Report 2021*. China Hydrogen Energy & Fuel Cells Industry Innovation Strategic Alliance.
- CHF. (2021). *Houston Region: Becoming a Global Hydrogen Hub*. Houston: Center for Houston's Future.
- CHF. (2022). *Houston as the epicenter of a global clean hydrogen hub*. Houston: Center for Houston's Future.
- Cockerill, R. (2021, July 1). Electrolyser Technologies. doi:July 2021
- Collins, L. (2022). *Chance is high that China will take over global hydrogen electrolyser market in similar way to solar sector: BNEF*. Retrieved from Recharge: <https://www.rechargenews.com/energy-transition/exclusive-chance-is-high-that-china-will-take-over-global-hydrogen-electrolyser-market-in-similar-way-to-solar-sector-bnef/2-1-1230106>
- Collins, L. (2022b, May 9). *EU backs green hydrogen subsidies as electrolyser firms vow to boost output tenfold by 2025*. Retrieved from Recharge: <https://www.rechargenews.com/energy-transition/eu-backs-green->

- hydrogen-subsidies-as-electrolyser-firms-vow-to-boost-output-tenfold-by-2025/2-1-1215495?utm\_term=recharge
- Consoli, C. (2017). *Global cost of carbon capture and storage*. Global Carbon Capture and Storage Institute.
- CTVC. (2022, August 22). *IRA and the new capital cost of climate #114*. Retrieved from Climate Tech VC: <https://www.ctvc.co/ira-and-the-new-capital-cost/>
- Cummins, Inc. (2020, November). *ELECTROLYZERS 101: WHAT THEY ARE, HOW THEY WORK AND WHERE THEY FIT IN A GREEN ECONOMY*. Retrieved from <https://www.cummins.com/news/2020/11/16/electrolyzers-101-what-they-are-how-they-work-and-where-they-fit-green-economy>
- Delte-EE. (2022). *Whitepaper - 2022 – the year to bridge the gap between ambition and reality for green hydrogen in Europe*. Edinburgh: Delta Energy & Environment Ltd.
- Department of Labor. (2022). *Occupational Employment and Wage Statistics (OEWS) Survey - May 2021 OEWS Estimates*. Washington D.C.: Bureau of Labor Statistics, Department of Labor. Retrieved from [www.bls.gov/oes](http://www.bls.gov/oes)
- DOE. (2022). *RFI # DE-FOA-0002698 RFI on Clean Hydrogen Manufacturing, Recycling, and Electrolysis*. Washington D.C.: U.S. Department of Energy - Office of Energy Efficiency & Renewable Energy.
- E-Bridge. (2022, July 8). *Hydrogen Price Index - Hydex*. Retrieved from E-Bridge: <https://www.e-bridge.com/#hydexmodal>
- ECHA. (2022). *European Electrolyser Summit - Joint Declaration*. Brussels: European Clean Hydrogen Alliance.
- EERE. (2022, 06 07). *United States Department of Energy - Office of Energy Efficiency & Renewable Energy*. Retrieved from Energy Materials Network: <https://www.energy.gov/eere/energy-materials-network/energy-materials-network>
- ENR. (2022). *ENR 2021 Top 500 Design Firms*. Retrieved from Engineering-News-Record: <https://www.enr.com/toplists/2021-top-500-design-firms-preview>
- European Commission. (2022, May 18). *REPowerEU: A plan to rapidly reduce dependence on Russian fossil fuels and fast forward the green transition*. Retrieved from REPowerEU: [https://ec.europa.eu/commission/presscorner/detail/en/IP\\_22\\_3131](https://ec.europa.eu/commission/presscorner/detail/en/IP_22_3131)
- FCHEA. (2020). *Roadmap to a US Hydrogen Economy*. Retrieved from <https://static1.squarespace.com/static/53ab1fee4b0bef0179a1563/t/5e7ca9d6c8fb3629d399fe0c/1585228263363/Road+Map+to+a+US+Hydrogen+Economy+Full+Report.pdf>
- Flyvberg, B. (2021). *Four Ways to Scale Up: Smart, Dumb, Forced, and Fumbled*. Oxford: Saïd Business School: University of Oxford.
- Fraunhofer ISE. (2021). *Cost forecast for low temperature electrolysis – technology driven bottom-up prognosis for PEM and alkaline water electrolysis systems*. Freiburg: Fraunhofer ISE. Retrieved from <https://www.ise.fraunhofer.de/content/dam/ise/de/documents/publications/studies/cost-forecast-for-low-temperature-electrolysis.pdf>
- GH2. (2022, 06 08). *The GH2 Green Hydrogen Standard*. Retrieved from Green Hydrogen Organisation: <https://gh2.org/our-initiatives/gh2-green-hydrogen-standard>
- Gilmer, B. (2018). *Proximity Counts: How Houston Dominates the Oil Industry*. Retrieved from Forbes: <https://www.forbes.com/sites/uhenergy/2018/08/22/proximity-counts-how-houston-dominates-the-oil-industry/?sh=18e35dac6107>
- Government of Canada. (2022, 02 04). *Graphite facts*. Retrieved from Natural Resources Canada: <https://www.nrcan.gc.ca/our-natural-resources/minerals-mining/minerals-metals-facts/graphite-facts/24027>
- Greater Houston Partnership. (2020). Retrieved from <https://www.houston.org/why-houston/industries/energy>
- Greater Houston Partnership. (2021). *Houston Facts 2021*. Houston: Greater Houston Partnership.

- Greater Houston Partnership. (2022). *Houston Business Insider*. Houston: Greater Houston Partnership.
- Groom, N. (2021, January 29). *Power plant linked to idled U.S. carbon capture project will shut indefinitely -NRG*. Retrieved from Yahoo! Finance: <https://finance.yahoo.com/news/power-plant-linked-idled-u-204526410.html>
- Gudde, N., Larive, J., & Yugo, M. (2019). *CO2 reduction technologies. Opportunities within the EU refining system (2030/2050)*. Brussels, Belgium: Concawe.
- Hall, K. (2022, 06 12). *Putting the Pressure on Hydrogen: A Look at Compressors and Pumps*. Retrieved from Gasworld.com: <https://www.gasworld.com/open-access/putting-the-pressure-on-hydrogen-a-look-at-compressors-and-pumps>
- Halliburton. (2022). *Sustainable Energy Solutions*. Retrieved from Halliburton: <https://www.halliburton.com/en/integrated-services/consulting/sustainable-energy-solutions>
- HETI. (2022). *Houston as the epicenter of a global clean hydrogen hub*. Houston: Houston Energy Transition Initiative.
- Hydrogen Council. (2021). *Hydrogen for Net-Zero - A critical Cost Competitive Energy Vector*. Brussels: Hydrogen Council, McKinsey & Company.
- Hydrogen Council. (2021b). *Policy Toolbox for Low Carbon and Renewable Hydrogen*. Brussels: Hydrogen Council.
- Hydrogenics. (2019, 02 21). *State of Play and Developments of Power-to-Hydrogen Technologies*. Retrieved from Hydrogenics: [https://etipwind.eu/wp-content/uploads/A2-Hydrogenics\\_v2.pdf](https://etipwind.eu/wp-content/uploads/A2-Hydrogenics_v2.pdf)
- IEA. (2021). *Global hydrogen review 2021*.
- IEA. (2021). *Hydrogen in Latin America*. Paris: International Energy Agency.
- IEA. (2022). *The Role of Critical Minerals in Clean Energy Transitions*. Paris: International Energy Agency.
- industryselect. (2020, January 30). *Top 9 U.S. Oil and Gas Machinery Manufacturers*. Retrieved from industryselect: <https://www.industryselect.com/blog/top-9-us-oil-and-gas-machinery-manufacturers>
- International Panel on Climate Change. (2018). *Carbon Dioxide Capture and Storage IPCC Report*.
- IRENA. (2020). *Green hydrogen cost*. Abu Dhabi: International Renewable Energy Agency.
- IRENA. (2021). *Making the Breakthrough - Green Hydrogen Policies and Technology Costs*. Abu Dhabi: International Renewable Energy Agency.
- IRENA. (2022). *Global Hydrogen Trade to Meet the 1.5C Climate Goal*. Abu Dhabi: International Renewable Energy Agency.
- IRENA. (2022). *World Energy Transition Outlook 2022*. Abu Dhabi: International Renewable Energy Agency.
- IRENA. (2022b). *Geopolitics of the Energy Transformation*. 2022: International Renewable Energy Agency.
- ISPT. (2022). *A One-Gigawatt Green Hydrogen Plant: Advanced Design and Total Installed Capital Costs*. The Netherlands: Institute for Sustainable Process Technology. Retrieved from <https://ispt.eu/media/ISPT-public-report-gigawatt-green-hydrogen-plant.pdf>
- James, B., Prosser, J., & Das, S. (2022). *HTE Stack Manufacturing Cost Analysis*. Arlington: Strategic Analysis Inc. Retrieved from <https://www.energy.gov/sites/default/files/2022-03/HTE%20Workshop-Strategic%20Analysis.pdf>
- KBR. (2021, 12 22). *KBR Awarded Study to Support Green Hydrogen Growth in Trinidad and Tobago*. Retrieved from KBR - Press Releases: <https://www.kbr.com/en/insights-news/press-release/kbr-awarded-study-support-green-hydrogen-growth-trinidad-and-tobago>
- Kranenburg, V. (2020). *E-Fuels: Towards a more sustainable future for truck transport, shipping and aviation*.
- Larson et al, E. (2021). *Net Zero America: Potential Pathways, Infrastructure and Impacts Final Report*. Princeton: Princeton University. Retrieved from <https://netzeroamerica.princeton.edu>
- LinkedIn. (2022). *Company Search*. Retrieved from LinkedIn: <https://www.linkedin.com/>

- Lomax, J. N. (2017, February 14). Retrieved from Texas Monthly: <https://www.texasmonthly.com/news-politics/evolution-energy-capital-world/>
- Lyubovsky et al., M. (2021, December 17). Cost of long-distance energy transmission by different carriers. *iScience*, p. 25. doi:<https://doi.org/10.1016/j.isci.2021.103495>
- Matthey. (2022). *GM management*. Retrieved from Johnson Matthey: <https://matthey.com/products-and-markets/pgms-and-circularity/pgm-management>
- Mayyas, A., & Mann, M. (2019). Emerging Manufacturing Technologies for Fuel Cells and Electrolyzers. *Procedia Manufacturing*, 508-515.
- Nel. (2021). *Investor day presentation*. Nel.
- NREL. (2018). *Annual Technology Baseline: Electricity*. Retrieved 2020, from Annual Technology Baseline: <https://atb.nrel.gov/electricity/>
- NREL. (2019). *Manufacturing Cost Analysis for Proton Exchange Membrane Water Electrolyzers*. Denver: National Renewable Energy Laboratory.
- OECD. (2018). *The Full Costs of Electricity Provision*. Paris, France: Organization for Economic Co-operation and Development.
- Office of the United States Trade Representative. (2019). *State Benefits of Trade*. Washington DC: United States. Retrieved from <https://ustr.gov/map/state-benefits/tx>
- Parkes, R. (2022, 6 22). *Biden invokes wartime legislation to ramp up US hydrogen electrolyser production, but what will this mean in practice?* Oslo: Recharge. Retrieved from RECHARGE: <https://www.rechargenews.com/energy-transition/biden-invokes-wartime-legislation-to-ramp-up-us-hydrogen-electrolyser-production-but-what-will-this-mean-in-practice-/2-1-1235045>
- Parkes, R. (2022, 05 18). *'So important' | Industry sets strict rules on what can be labelled as 'green' hydrogen*. Retrieved from Recharge - Energy Transition: [https://www.rechargenews.com/energy-transition/so-important-industry-sets-strict-rules-on-what-can-be-labelled-as-green-hydrogen/2-1-1220940?utm\\_source=email\\_campaign&utm\\_medium=email&utm\\_campaign=2022-05-19&utm\\_term=recharge&utm\\_content=hydrogen](https://www.rechargenews.com/energy-transition/so-important-industry-sets-strict-rules-on-what-can-be-labelled-as-green-hydrogen/2-1-1220940?utm_source=email_campaign&utm_medium=email&utm_campaign=2022-05-19&utm_term=recharge&utm_content=hydrogen)
- Parkes, R. (2022b, June 29). *Don't blame us - Electrolyser producers being held back by lack of green hydrogen FIDs*. Retrieved from Recharge News: <https://www.rechargenews.com/energy-transition/dont-blame-us-electrolyser-producers-being-held-back-by-lack-of-green-hydrogen-fids/2-1-1248444>
- Port of Houston. (2022, 05). *Statistics*. Retrieved from Port of Houston: <https://porthouston.com/about-us/statistics/>
- Rhodes et al., J. (2021). *Renewable Electrolysis in Texas: Pipelines versus Power Lines*. Austin: H2@UT.
- S&P Global. (2022, 07 08). *What are Platts Hydrogen Assessments?* Retrieved from S&P Global Commodity Insights: <https://www.spglobal.com/commodityinsights/en/our-methodology/price-assessments/energy-transition/hydrogen-price-assessments>
- Schlumberger. (2022). *Annual Report 2021*. Paris: Schlumberger. Retrieved from <https://investorcenter.slb.com/static-files/d8eed2fd-eee7-4491-ac47-e199d5055bb8>
- Startup Genome. (2022a). *The Global Startup Ecosystem report*. San Francisco: Startup Genome.
- Startup Genome. (2022b). *The Global Startup Ecosystem Report - Cleantech Edition*. San Francisco: Startup Genome.
- Texas Economic Development Corporation. (2022, 05 30). *Advanced Manufacturing in Texas*. Retrieved from Texas Economic Development Corporation: <https://businessintexas.com/business-sectors/advanced-manufacturing/>
- TNO. (2020). *Electrolysers: : opportunities for the Dutch manufacturing industry*. The Hague: Nederlandse Organisatie voor Toegepast Natuurwetenschappelijk Onderzoek.

- UH Energy. (2022, July 13). *Project Showplace Texas Gulf Coast*. Retrieved from University of Houston: [https://www.uh.edu/uh-energy/research/project-showplace/#:~:text=Project%20SHOWPLACE%20\(%20Storing%20Hydrogen%20from,offshore%20wind%20power%20%26%20hydrogen%20generation%20%26](https://www.uh.edu/uh-energy/research/project-showplace/#:~:text=Project%20SHOWPLACE%20(%20Storing%20Hydrogen%20from,offshore%20wind%20power%20%26%20hydrogen%20generation%20%26)
- University of Houston Energy Fellows. (2018, 08 22). *Proximity Counts: How Houston Dominates the Oil Industry*. Retrieved from Forbes: <https://www.forbes.com/sites/uhenery/2018/08/22/proximity-counts-how-houston-dominates-the-oil-industry/?sh=18e35dac6107>
- US Census. (2021, December 16). *County Business Patterns by Industry: 2019*. Retrieved from United States Census Bureau: <https://www.census.gov/library/visualizations/interactive/county-business-patterns-by-industry-2019.html>
- US Congress. (2022). *H.R.5376 - Inflation Reduction Act of 2022*. Washington D.C.: 117th Congress (2021-2022). Retrieved from <https://www.congress.gov/bill/117th-congress/house-bill/5376/text?q=%7B%22search%22%3A%5B%22Inflation+Reduction+Act%22%2C%22Inflation%22%2C%22Reduction%22%2C%22Act%22%5D%7D&r=1&s=2>
- USDOE. (2021). *H2NEW Hydrogen (H2) from Next-generation Overview*. Washington D.C.: U.S. Department of Energy.
- USDOE. (2022, 06 11). *On-Site and Bulk Hydrogen Storage*. Retrieved from Hydrogen and Fuel Cell Technologies Office: <https://www.energy.gov/eere/fuelcells/site-and-bulk-hydrogen-storage>
- USDOE. (2022). *Water Electrolyzers and Fuel Cell Supply Chain*. U.S. Department of Energy.
- USDOE. (2022b). *Platinum Group Metal Catalysts*. Washington DC: U.S. Department of Energy.
- USEIA. (2022, May 10). *U.S. ammonia prices rise in response to higher international natural gas prices*. Retrieved from US Energy Information Agency - TODAY IN ENERGY: <https://www.eia.gov/todayinenergy/detail.php?id=52358>
- USGS. (2017). *Critical Mineral Resources of the United States - Economic and Environmental Geology and Prospects for Future Supply*. Washington DC: U.S. Geological Survey. doi:<https://doi.org/10.3133/pp1802>
- USGS. (2022). *National Minerals Information Center*. Retrieved from US Geological Survey: <https://www.usgs.gov/centers/national-minerals-information-center>
- WRI. (2022, May 23). *Carbon Capture, Utilization and Storage (CCUS) Tax Credit Amendments Act of 2021 and Negate Emissions to Zero (NET Zero) Act of 2021*. Retrieved from World Resources Institute: <https://www.wri.org/update/45q-enhancements>
- Yan, Y. (2020). *Anion Exchange Membrane Water Electrolysis*. Retrieved from [https://ebruary.net/134227/engineering/anion\\_exchange\\_membrane\\_water\\_electrolysis](https://ebruary.net/134227/engineering/anion_exchange_membrane_water_electrolysis)
- Yara. (2019, November 13). *Yara announces closure of Trinidad ammonia plant*. Retrieved from Yara Corporate Releases: <https://www.yara.com/corporate-releases/yara-announces-closure-of-trinidad-ammonia-plant/>
- Yodwong et al., B. (2020). AC-DC Converters for Electrolyzer Applications: State of the Art and Future Challenges. *Electronics*, 31. doi:<https://doi.org/10.3390/electronics9060912>
- Zorpette, G. (2022, August 17). *2022—The Year the Hydrogen Economy Launched? The Inflation Reduction Act and the war in Ukraine pump billions into clean hydrogen R&D*. Retrieved from IEEE Spectrum: <https://spectrum.ieee.org/hydrogen-economy-inflation-reduction-act>